



**Graphic Communication
(National 5): question paper**

Candidate evidence

Candidate 6 evidence

Total marks — 65
Attempt ALL questions

1. The website homepage for a fitness company is shown below.

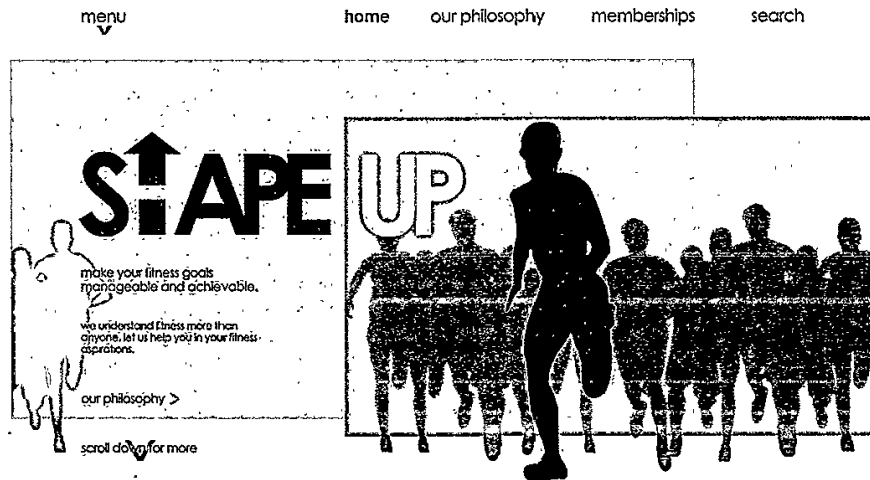

- (a) Explain two ways the designer has successfully created a modern and simple website homepage.

2

- the designer has used a sans serif font, which is modern and simple.
- the designer only used
- the designer has used a very simple color palette.

1. (continued)

(b) Describe two ways the graphic designer has used each of the following design elements and principles in the layout.

You may annotate the graphic on the opposite page to support your answer.

(i) Alignment

2

• the main body of text is left-

aligned with the title

• the main runner is top-aligned

with the red box.

(ii) Depth

2

• the main runner is darker

than the other runners, implying depth.

• the text over the runner on the left.

(iii) Contrast

2

• the large logo compared to the smaller text underneath it.

• the black of the heading on the white-space background.

(c) Explain two advantages to the fitness company of promoting their company online rather than in printed media.

2

• a wider audience can see it.

• don't have to spend any money

• can easily make changes to the promotion

[Turn over

2. A 3D CAD illustration of a bicycle lock casing, and an orthographic drawing of Part A, are shown below.

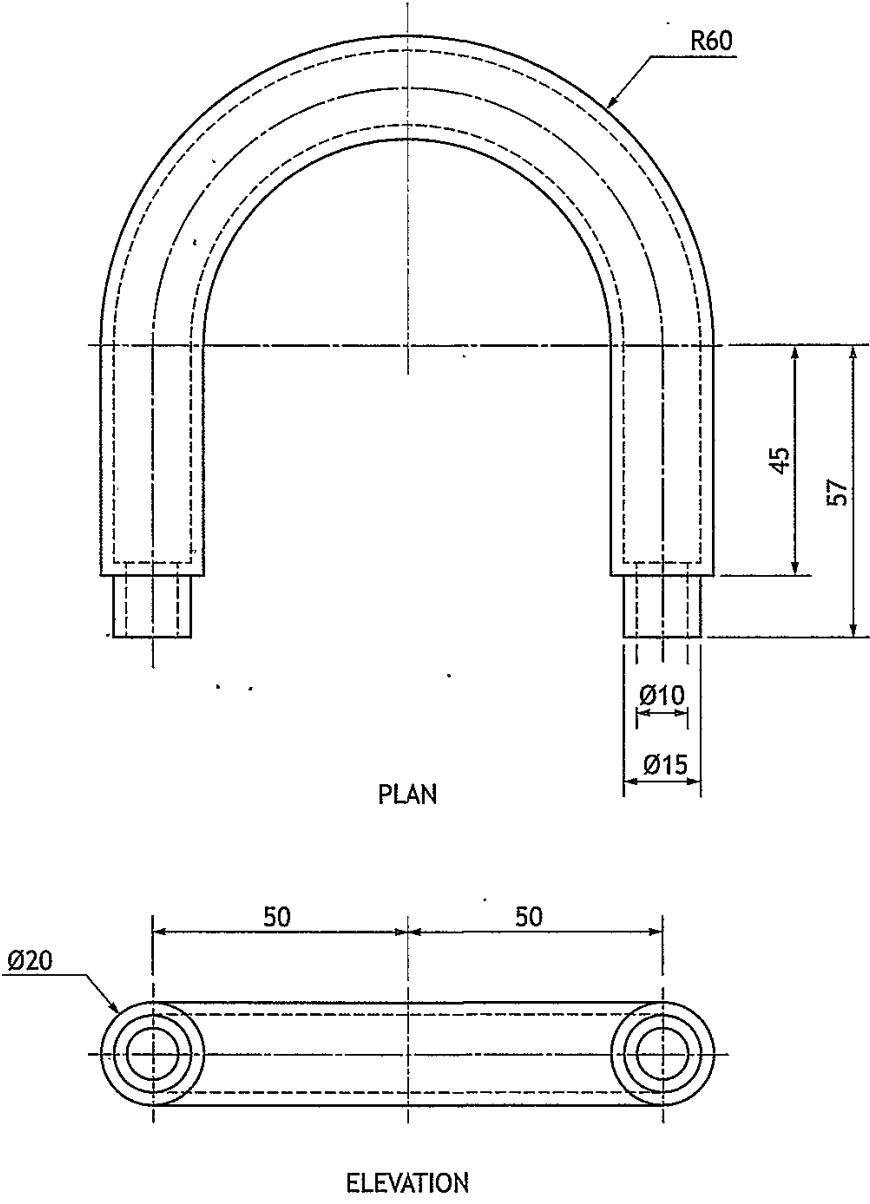
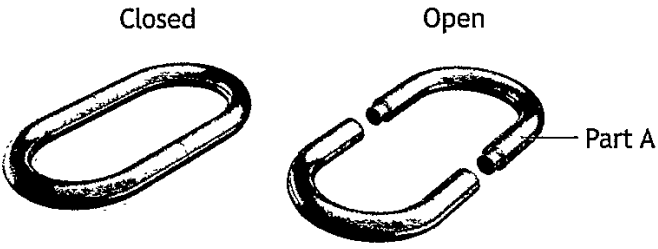

2. (continued)

- (a) Describe, using the correct dimensions and 3D CAD modelling terms, how you would use 3D CAD software to model Part A.

You may use sketches to support your answer.

6

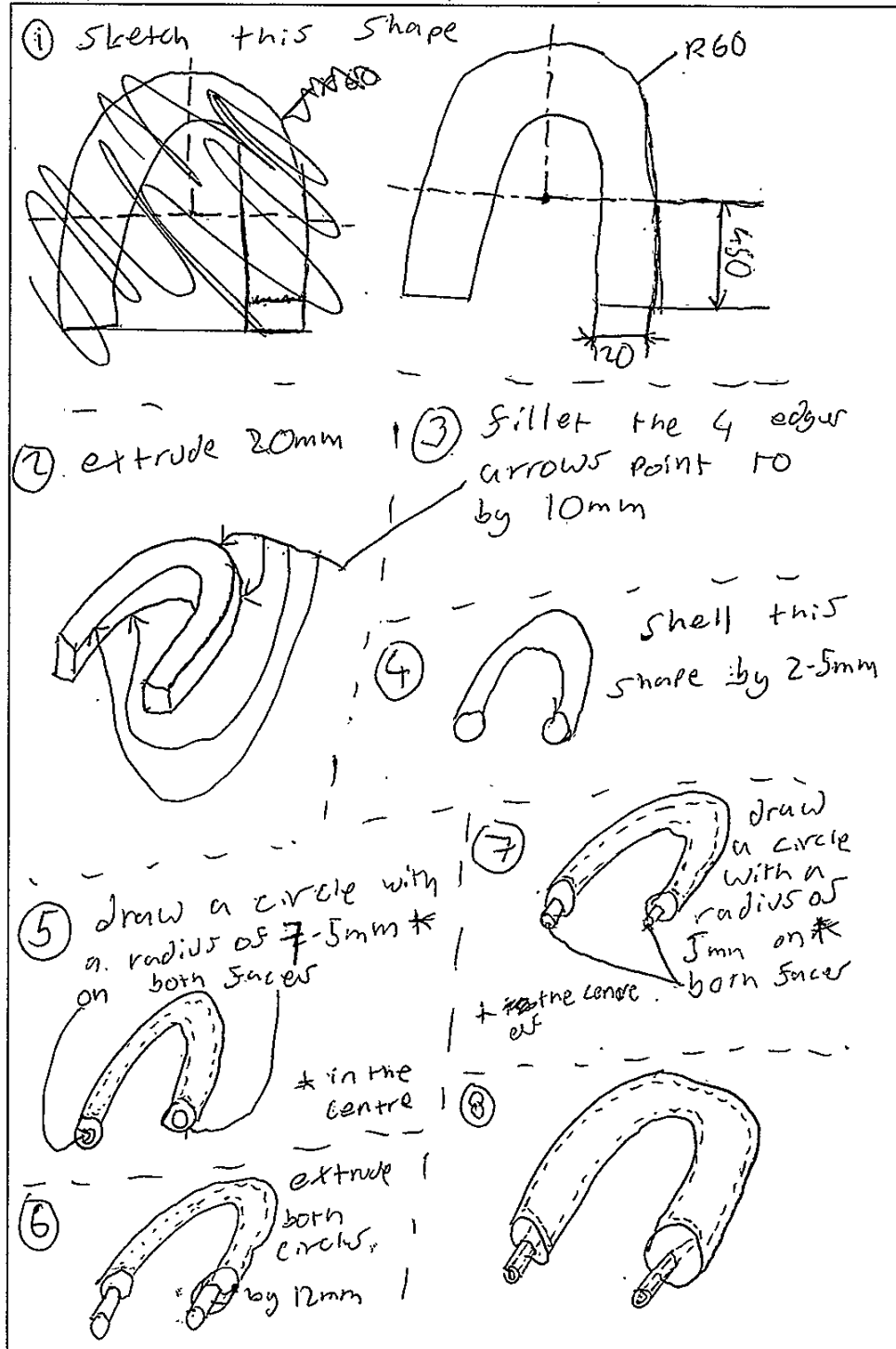

2. (continued)

3D CAD illustrations of the bicycle lock with its packaging and a drawing of the packaging are shown.

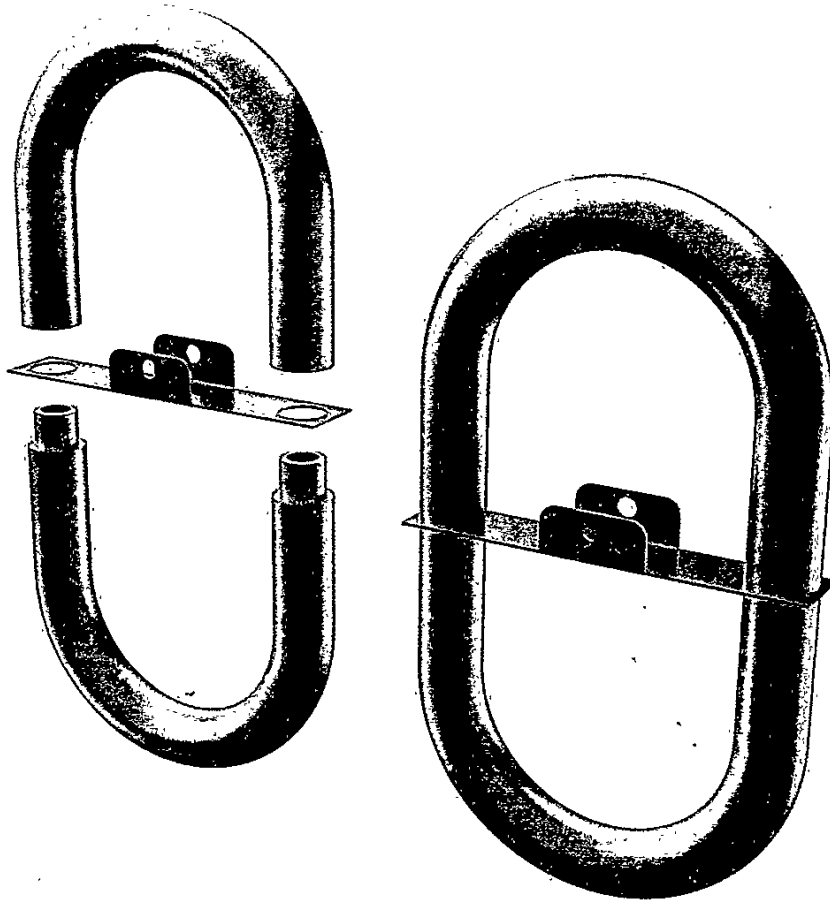

The packaging sleeve for the bicycle lock is made from card and fits between both parts of the lock. A surface development of the packaging sleeve is shown below.

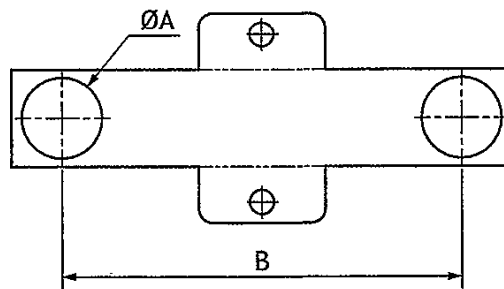

NOTE: The thickness of the card is not shown and the surface development is not to scale.

2. (continued)

(b) Calculate the minimum dimensions on the surface development for

(i) diameter A 45 1

(ii) length B 100 1

(c) Describe how the environmental impact of manufacturing the packaging sleeve can be reduced. 1

use a biodegradable packaging instead

[Turn over

3. A designer has created preliminary sketches for a ceiling-mounted display sign for an airport. The preliminary sketches are shown below.

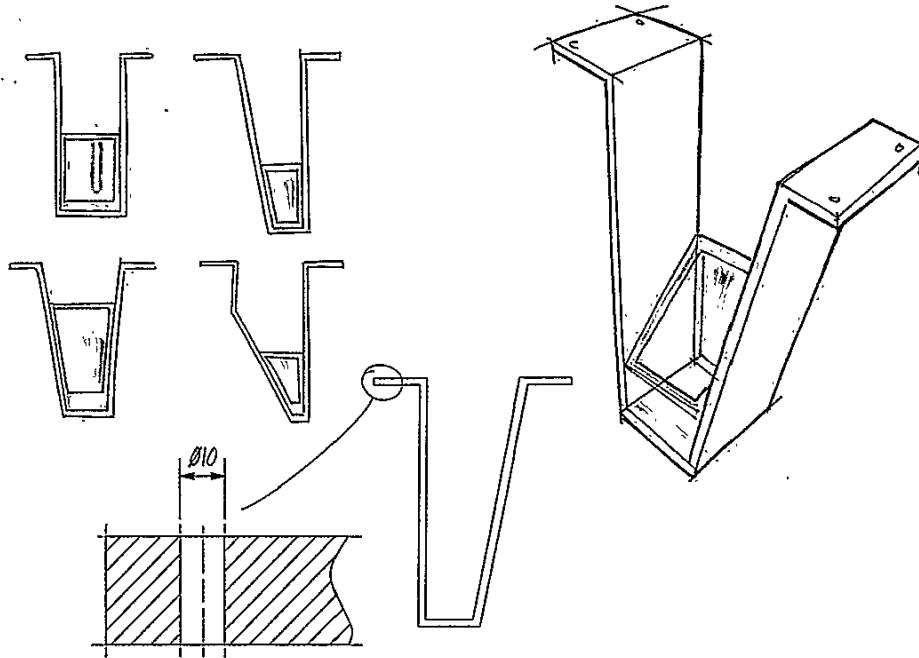

- (a) Explain the purpose of preliminary sketches.

2

to give an idea of what the final product will look like without fully committing to it.

- (b) State two input devices that could be used to make a digital copy of the preliminary sketches.

2

Camera
Scanner

3. (continued)

Two pictorial views of the display sign are shown below.

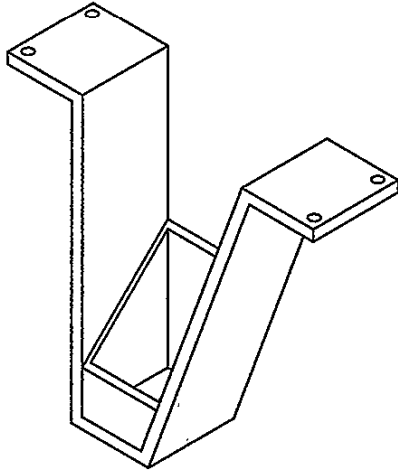

Pictorial A

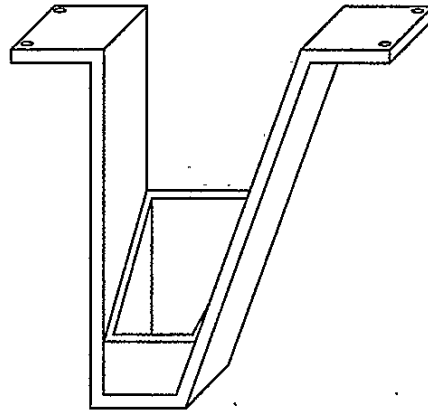

Pictorial B

(c) State the names of the pictorial views.

2

Pictorial A isometric

Pictorial B perspective

[Turn over

3. (continued)

- (d) The designer used constraints to assemble both parts of the display sign.

The before and after of stage 1 of the assembly is shown below. The grey areas show the surfaces that were constrained in stage 1.

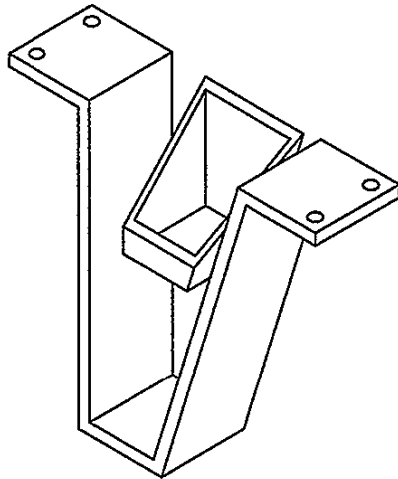

Before

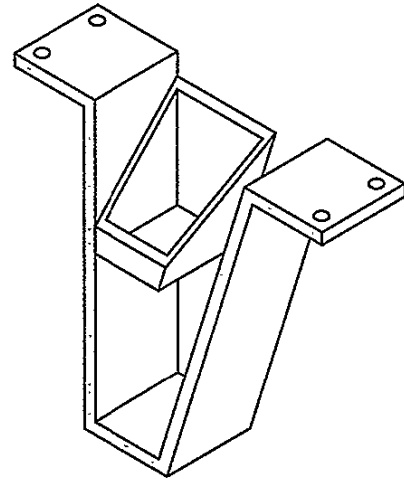

After

- (i) State the name of the CAD constraint used above.

1

align

- (ii) State the names of two other constraints used in 3D CAD modelling.

2

• centre-axis

• mate

- (e) The designer added more parts to the assembly from a CAD library.

Explain one advantage to the designer of using a CAD library.

1

• you save alot of time due to you

not having to create the object yourself.

3. (continued)

The finished production drawing of the assembly is shown below.

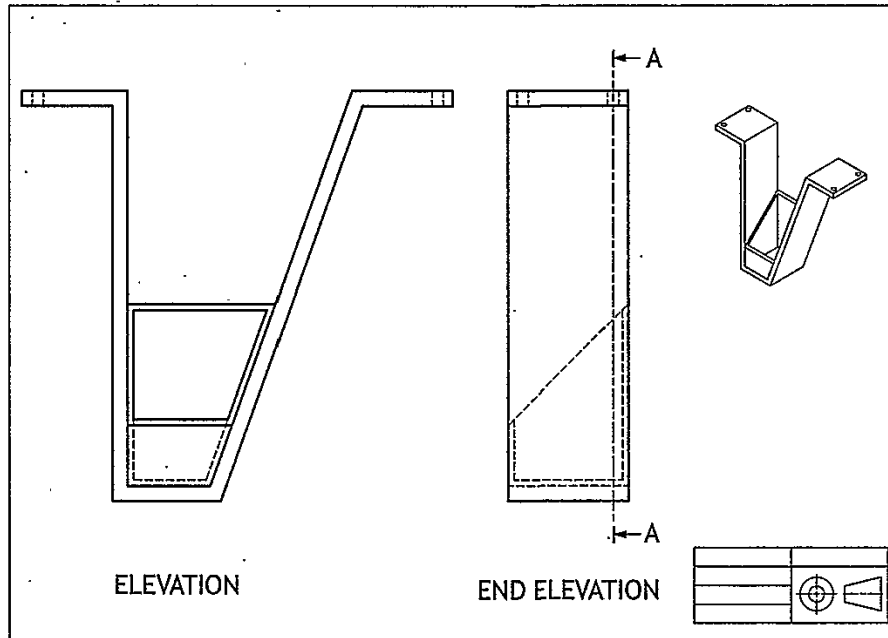

3. (continued)

(f) Identify the correct sectional end elevation A-A from the production drawing shown opposite, by ticking (✓) a box below.

1

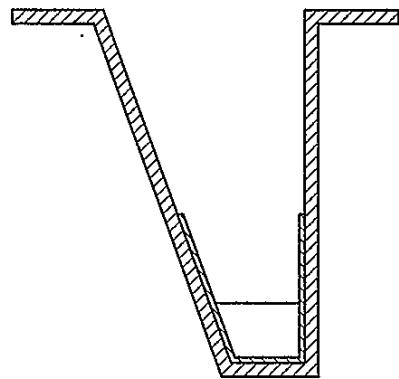
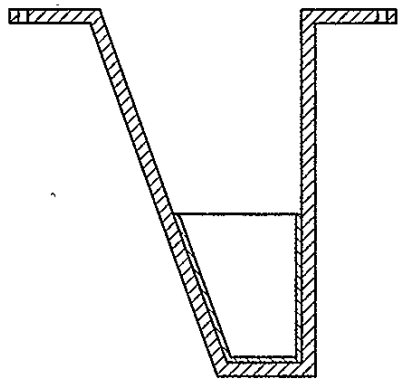
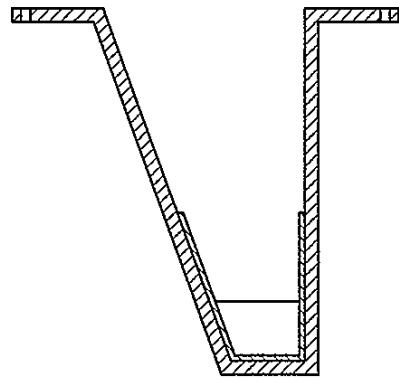
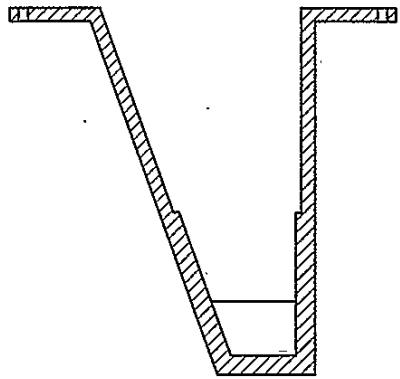

[Turn over

3. (continued)

Two ideas for the airport signs are shown below.

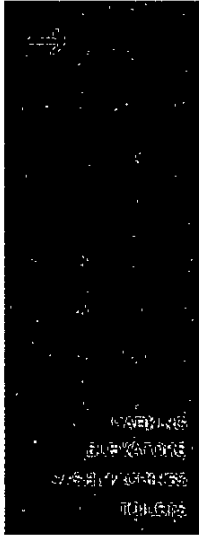

Sign 1

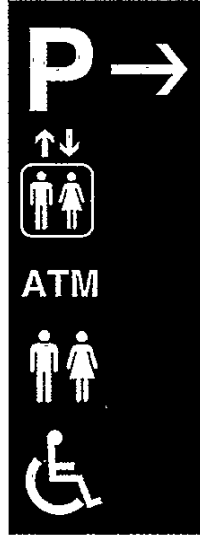

Sign 2

- (g) Explain, giving two reasons, why sign 2 is more appropriate for the airport sign.

2

• Sign 2 is easier to understand at a glance, as when you are in the airport, you are typically in a rush

• the symbols are more universally understood.

4. A graphic designer has produced an instruction manual for a beehive, shown below.

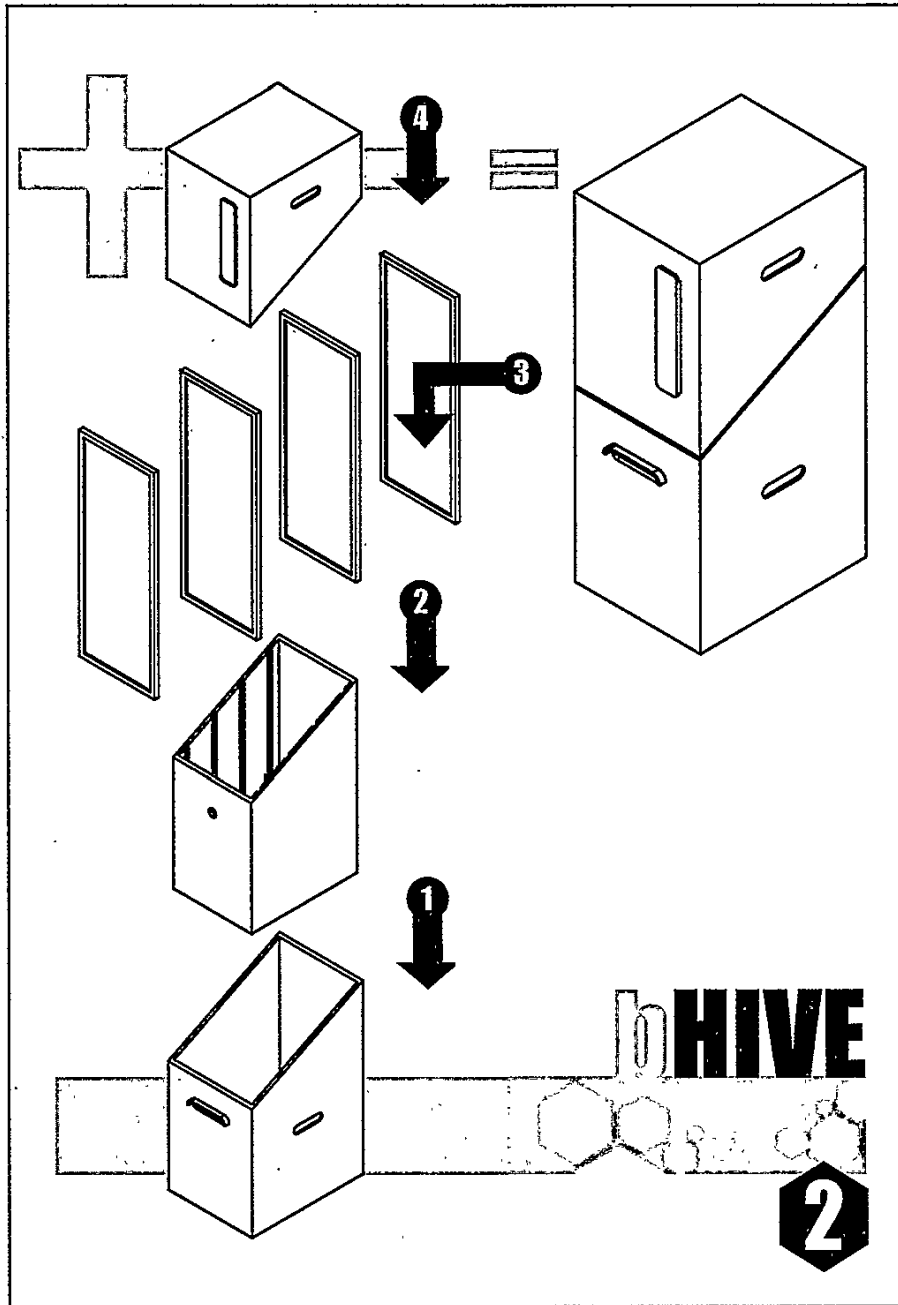

4. (continued)

(a) Explain an advantage to both the user and the manufacturer of not including text within the instruction manual.

(i) User you can read it no matter which 1
language you speak

(ii) Manufacturer doesn't have to make the same 1
manual in a variety of languages.

Before the final printing of the instruction manual several changes were made to reduce environmental impact.

(b) Describe one change that could be made to reduce the amount of ink used in the instruction manual opposite. 1

rather than filling the arrows with
black ink, just have the outline of
the arrow and number visible.

[Turn over

4. (continued)

The beehives are available in both primary and secondary colours. The lid and base are sold separately to allow customers to personalise their colour combinations.

- (c) A customer wants to purchase a red lid and a contrasting base.

State the name of a suitable colour.

1

blue

- (d) A customer wants to purchase a violet base and a harmonising lid.

State the name of a suitable colour.

1

red

- (e) A customer plans to purchase a beehive for use in a school's garden, they have selected both parts in primary colours.

- (i) State the name of two primary colours that could be purchased.

2

• red

• blue

- (ii) Explain why primary colours are suitable for a school garden.

1

because they will stand out in
the school garden.

4. (continued)

A range of vinyl wraps are being created for the beehive.

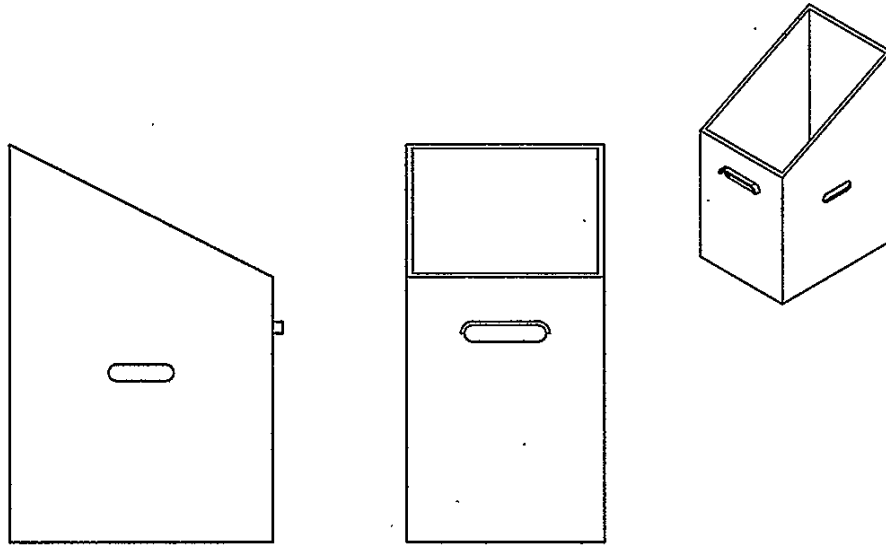

Base of beehive

- (f) (i) Identify the correct surface development used to create the vinyl wrap for the base of the beehive by ticking (✓) a box below.

1

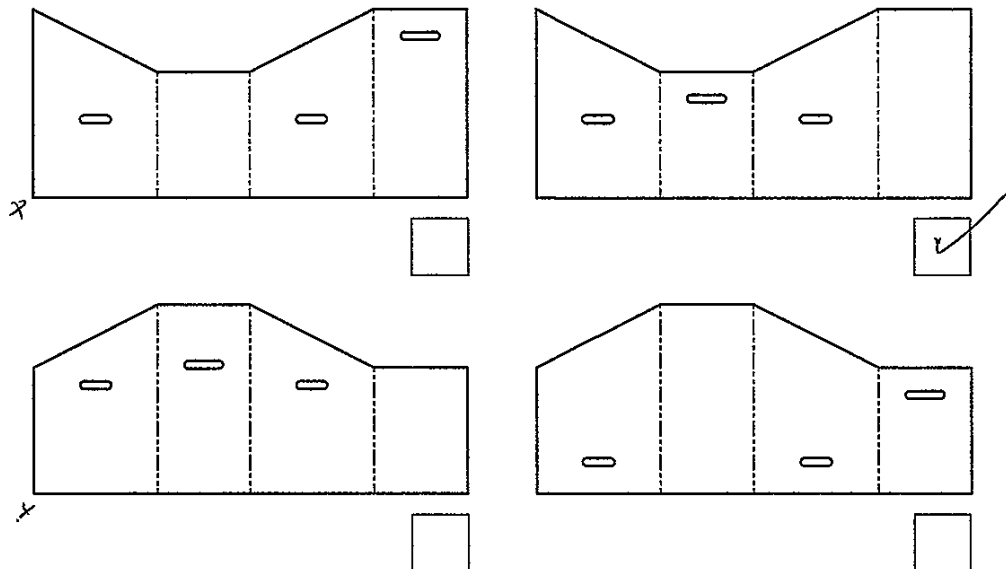

[Turn over

4. (f) (continued)

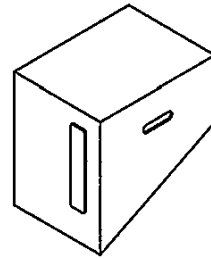
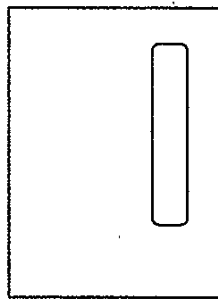
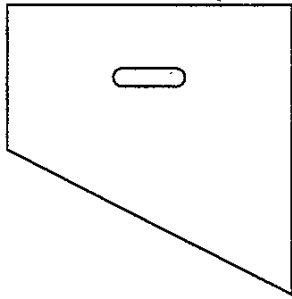

Lid of beehive

4. (f) (continued)

(ii) Identify the correct surface development to create the vinyl wrap for the lid of the bee hive by ticking (✓) a box below.

1

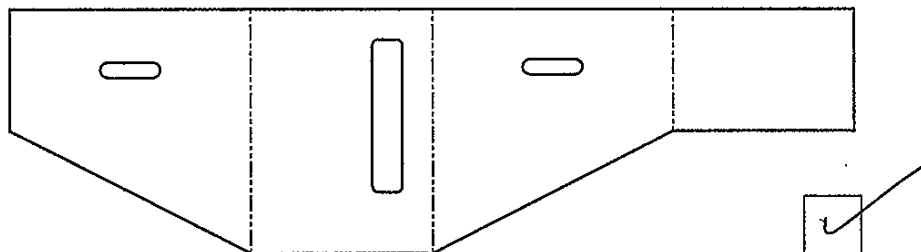
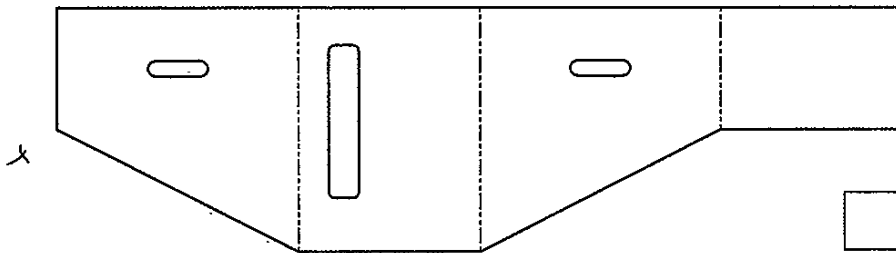
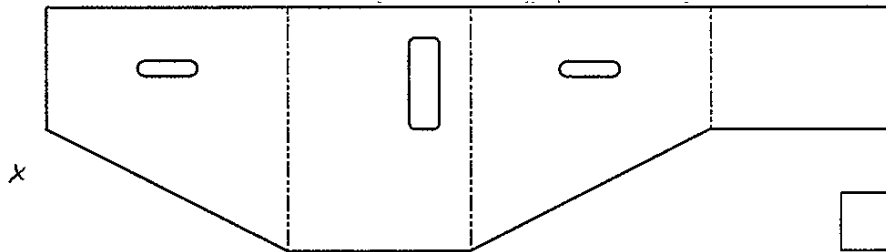
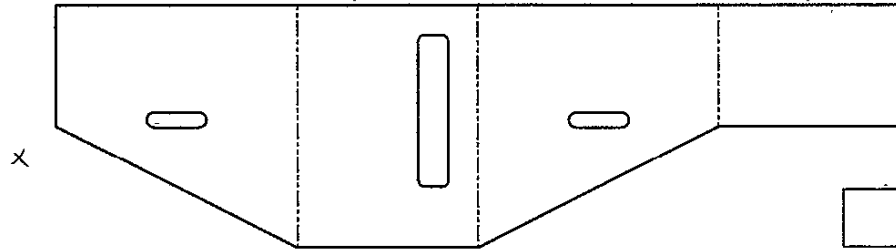

[Turn over

5. A new range of salt and pepper shakers are being developed.
A 3D CAD illustration of the salt and pepper shakers is shown below.

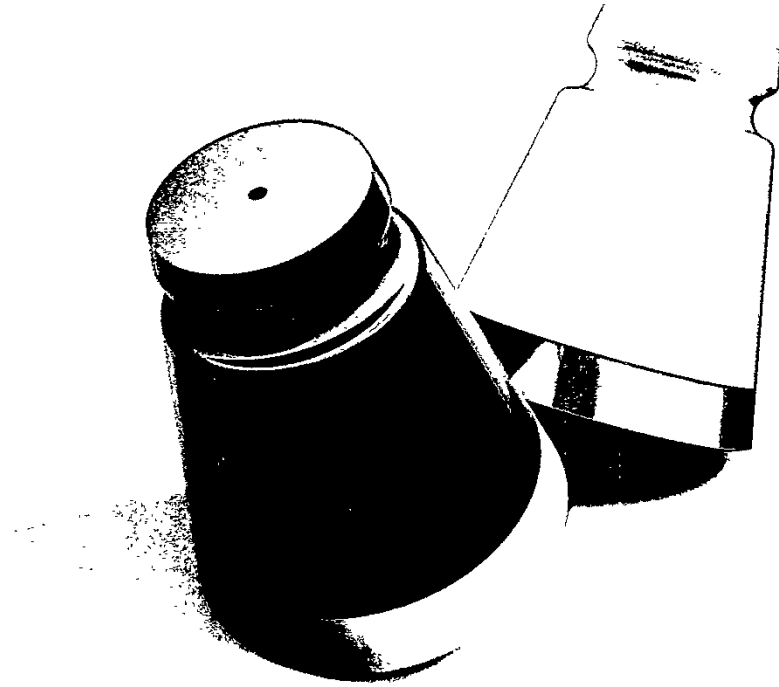

5. (continued)

A series of 2D drawing tools were used when modelling the shaker.

- (a) State the name of the 2D CAD drawing tool highlighted in red that is used at each stage.

3

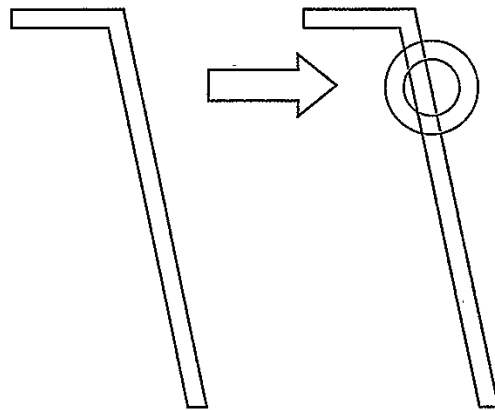

(i) tool used: draw circle

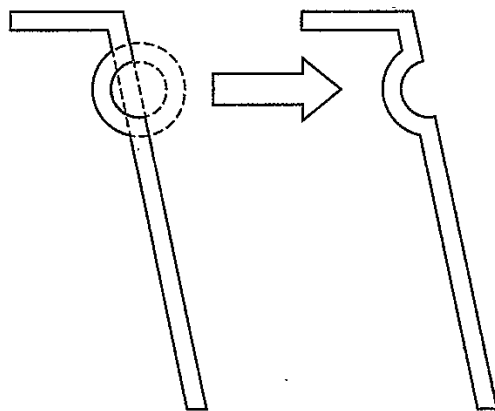

(ii) tool used: trim

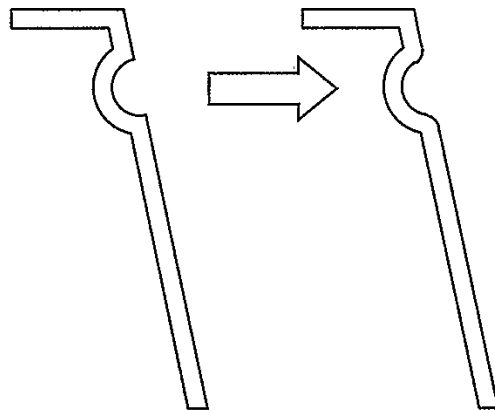

(iii) tool used: Fillet

5. (continued)

The base of the shaker will be made in a range of different woods. For promotional purposes the designer produced a 3D CAD illustration.



- (b) State the name of the technique used to give the greyscale model the appearance of wood.

1

shade

- (c) Describe two benefits of using 3D CAD models for manufacturing.

2

• very easy to edit.

• helps to visualize what it would look like in real life.

The initial renders were dark, pixelated and poor quality.

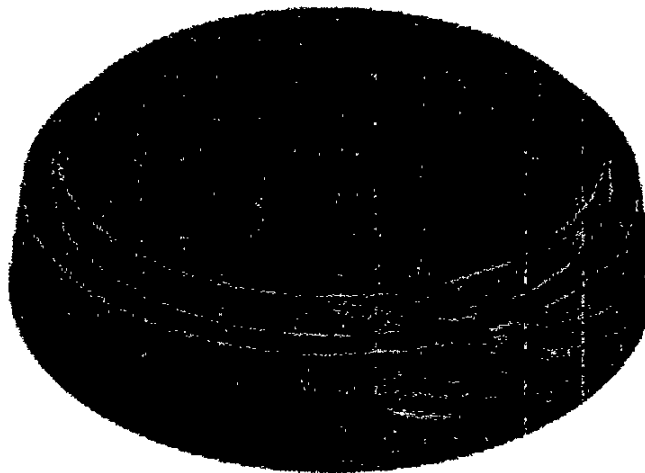

- (d) Describe one way the designer could improve the final renders.

1

Use a different file type.

5. (continued)

Modifications were made to the base section of the shaker. A sealing ring was added to stop the two sections separating.

The designer's development sketches for the changes are shown below.

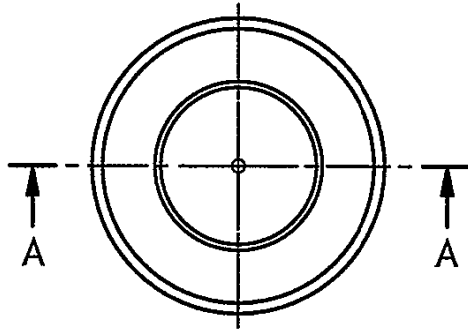

PLAN

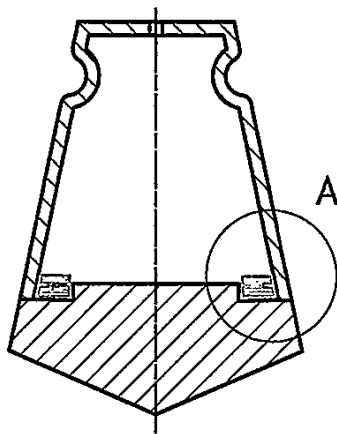

Section A-A

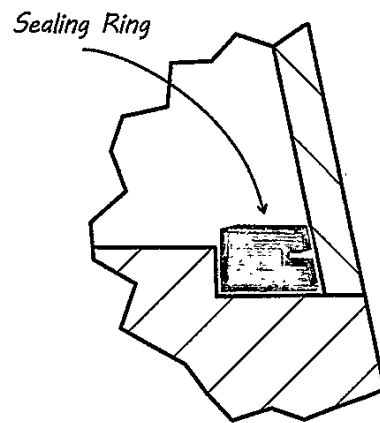

Detail A

5. (continued)

(e) Describe, using 3D CAD modelling techniques, how the sealing ring would be modelled.

Do not refer to dimensions. You may annotate the line drawing on the opposite page and use sketches to support your answer.

3

① use the line tool to create this shape

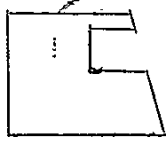

~~② the shape is revolved~~

② revolve the shape from ① around the centre axis a full 360°

6. The Scottish Space Exploration Association (SSEA) are launching a proposal for a base on Mars.

Three promotional badges have been developed for the proposal.



Badge 1



Badge 2



Badge 3

Describe one way the designer has used the following design elements and principles in any of the badges.

- (a) (i) Dominance 1
 on badge 1. an advancing red colour
 is next to a receding blue colour, showing dominance
- (ii) Line 1

- (iii) Unity 1
 on 'badge 1' the same font
 is used all over, creating a sense of unity.
- (b) (i) State whether the font style used in the badges above is Serif or Sans
 Serif. 1
 sans serif
- (ii) Explain why this font style is a suitable choice. 1
 it is modern looking, due to the
 simple design, modern implies futuristic
 which implies space.

6. (continued)

Detail from badge 3 is shown below.



(c) State the name of the two DTP techniques applied to the word 'expedition'. 2

Technique 1 text along a path

Technique 2 Bold

[Turn over

6. (continued)

It is proposed that a Mars base will be constructed using identical pods arranged in different ways.

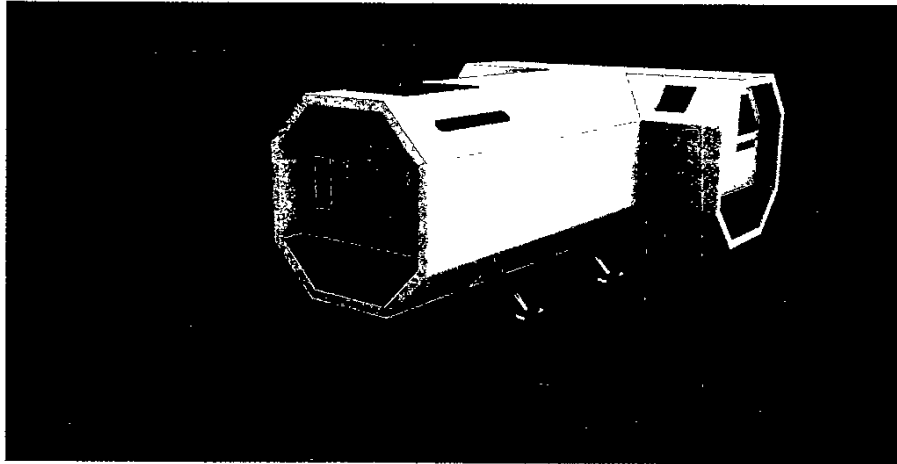

Orthographic elevations and a pictorial view of a single pod are shown below.

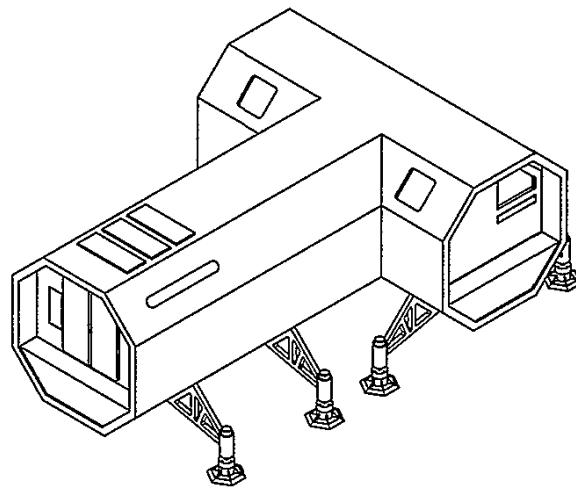

Pictorial View

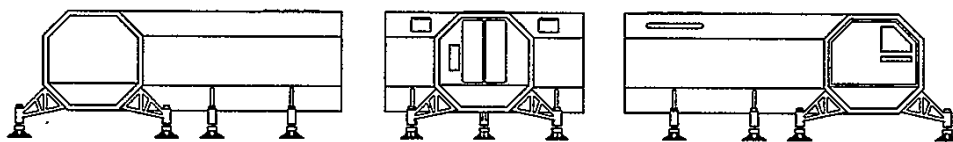

End Elevation

Elevation

End Elevation

6. (continued)

(d) Several arrangements are shown below. The pod legs have been removed to simplify the drawings.

Identify the two correct arrangements by ticking (✓) two boxes below.

2

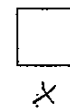
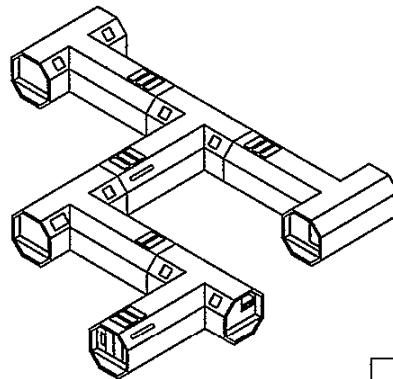
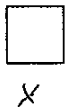
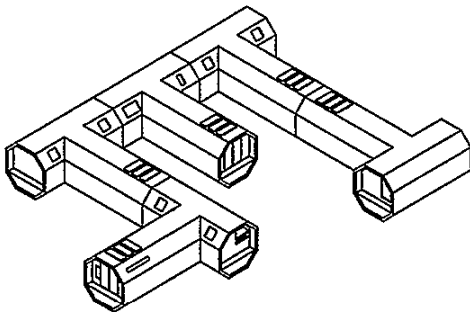
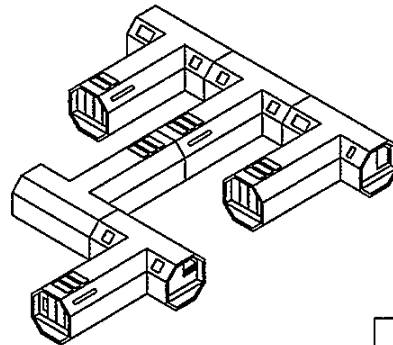
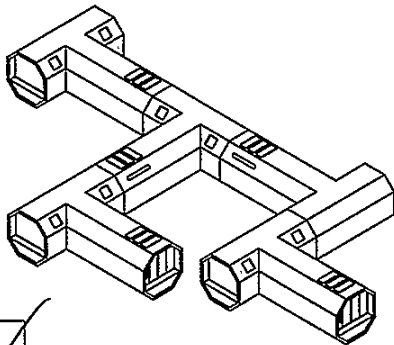
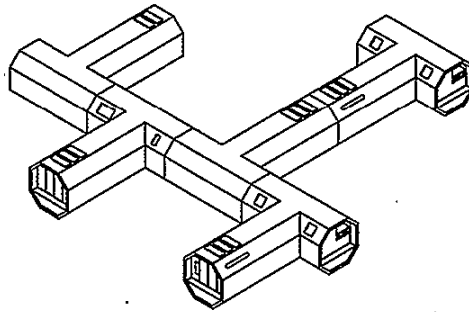
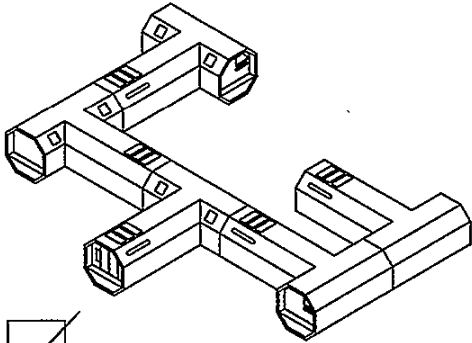

[Turn over

6. (continued)

(e) An exploded pictorial of a pod leg is shown below.

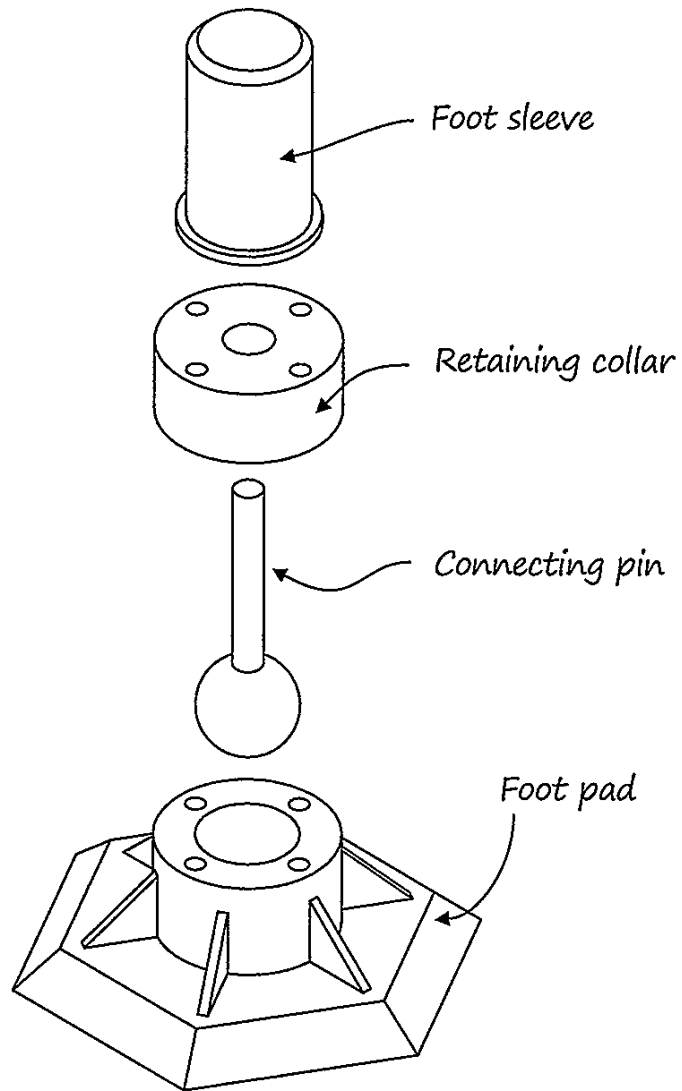

6. (e) (continued)

Identify the foot sleeve, retaining collar, connecting pin and foot pad by labelling the sectional elevation.

4

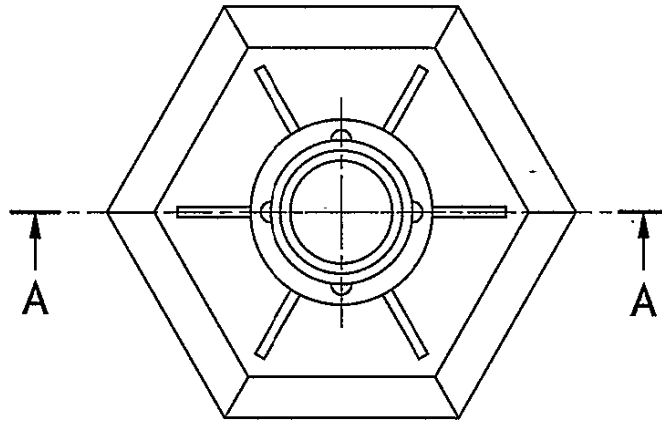

NOTE:
Centre lines
removed
for clarity

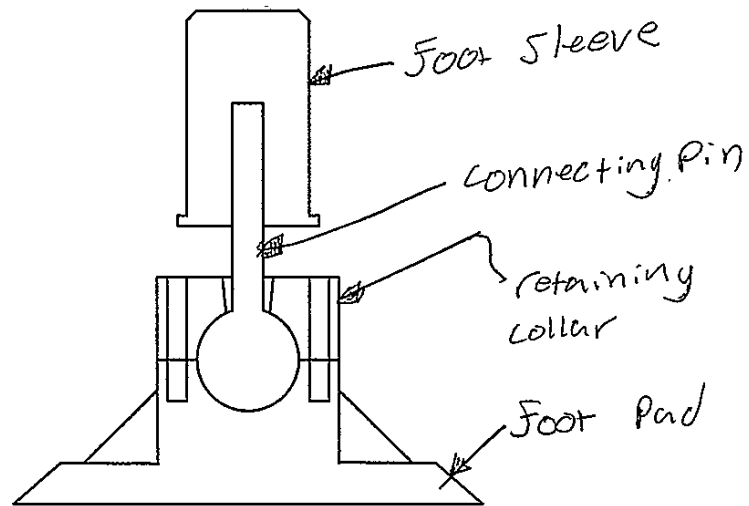

Sectional Elevation A-A

[END OF QUESTION PAPER]

6. (e) (continued)

Identify the foot sleeve, retaining collar, connecting pin and foot pad by labelling the sectional elevation.

4

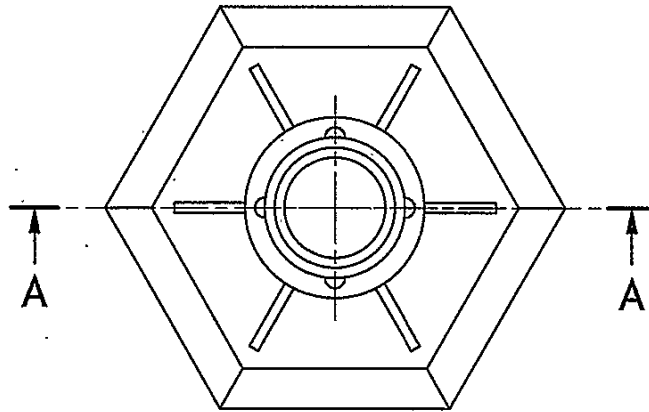

NOTE:
Centre lines
removed
for clarity

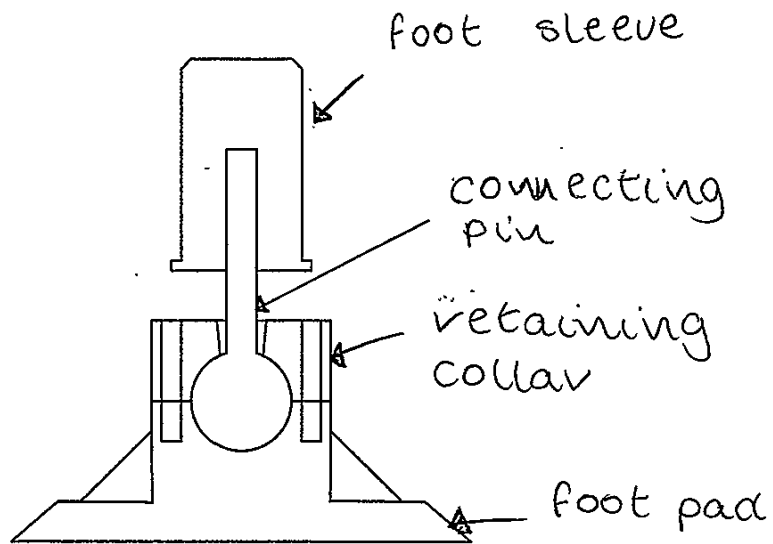

Sectional Elevation A-A

[END OF QUESTION PAPER]