

# Candidate 1 evidence

MARKS  
DO NOT  
WRITE IN  
THIS  
MARGIN

Total marks — 60  
Attempt ALL questions

1. A mirror is shown below.

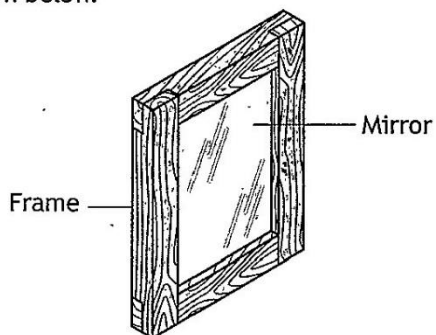

The mirror frame is made using corner halving joints.

As part of the design process various other joints were considered, three of which are shown.

(a) Name the joints shown.

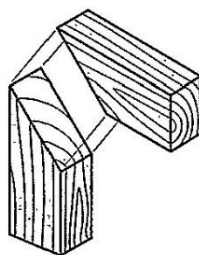

(i)                     butt joint                     1

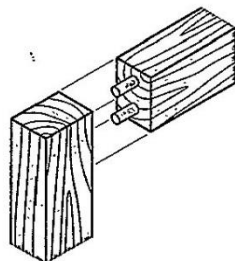

(ii)                     dowel joint                     1

**MARKS** DO NOT  
WRITE IN  
THIS  
MARGIN

1. (a) (continued)

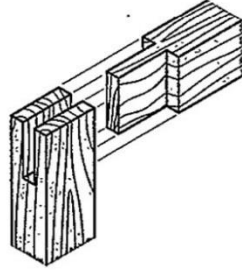

(iii) Half through housing 1

[Turn over

MARKS  
DO NOT  
WRITE IN  
THIS  
MARGIN

1. (continued)

The corner halving joint used in the mirror frame is shown below.

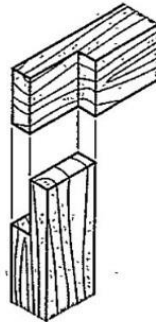

An important part of making any joint is marking out.

There are four stages in the marking out process.

- (b) Describe three stages in the marking out process in the table below. You may use sketches to support your answer.

The stages must be in the correct order.

The final stage is completed for you.

3

Sequence	Process
Stage 1	<p>Mark out the <del>width</del><sup>depth</sup> using a steel rule and a pencil</p>
Stage 2	<p>using a marking gauge measure the <del>depth</del><sup>width</sup> and mark out</p>
Stage 3	<p>use a <del>hand</del><sup>tenon saw</sup> to cut <del>down</del> out the waste wood.</p>
Stage 4	Mark the waste wood.

MARKS  
DO NOT  
WRITE IN  
THIS  
MARGIN

1. (continued)

The mirror frame is recessed to allow the mirror to be fitted, as shown below.

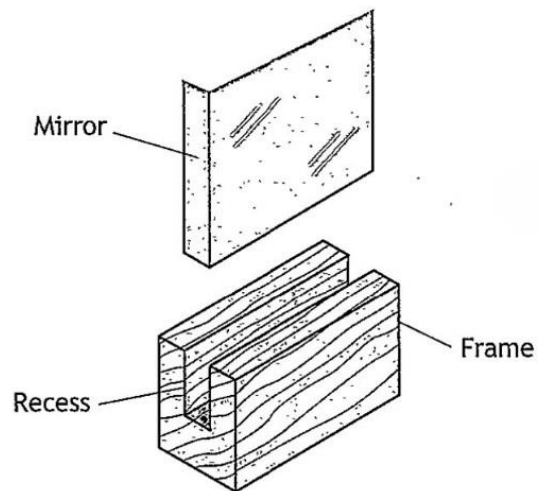

The tool shown below is used to cut the recess.

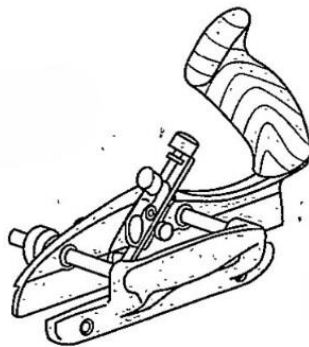

(c) Name this tool.

1

plough plane

[Turn over

**MARKS** DO NOT WRITE IN THIS MARGIN

1. (continued)

Various types of woods were considered to make the mirror frame.

(d) Complete the table below identifying if the woods listed are hardwood or softwood.

The first one is completed for you.

4

Wood		Hardwood/Softwood
Meranti		Hardwood
Oak	(i)	Hardwood
Ash	(ii)	Soft wood
Cedar	(iii)	hard wood
Larch	(iv)	softwood

It was decided to use softwood to make the mirror frame.

(e) Describe two environmental reasons for selecting a softwood instead of a hardwood.

2

- 1 hardwoods are very old and big and there are very little left which would destroy the ecosystem
- 2 lots of animals live in these trees which would destroy their habitats.

The mirror frame requires a finish to be applied which will protect the wood and show off the natural wood grain.

(f) State a suitable finish.

1

varnish

2. A table is shown below.

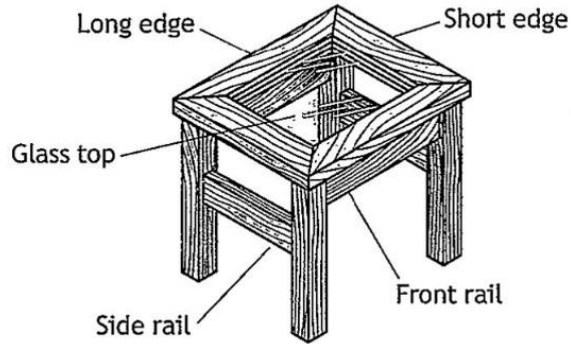

DO NOT  
WRITE IN  
THIS  
MARGIN

The diagram below shows the working drawings for the table.

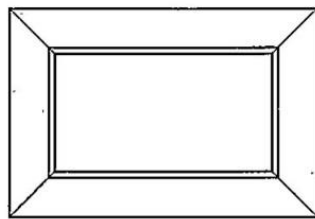

Plan

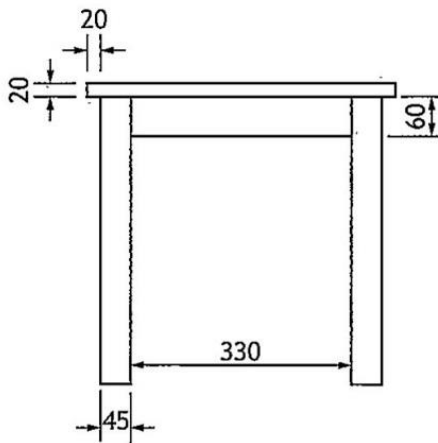

Elevation

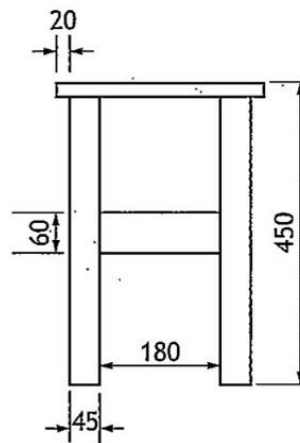

End Elevation

Front rail

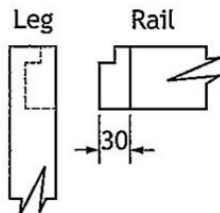

Side rail

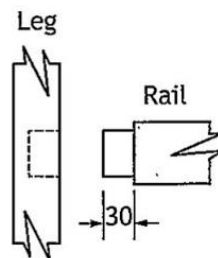

Note: The rails are joined to the legs using the joints shown in the drawings above. All sizes are in millimetres.

2. (continued)

MARKS

DO NOT  
WRITE IN  
THIS  
MARGIN

- (a) Complete the cutting list below, using the information provided in the working drawings shown opposite.

6

Part	Number	Length	Breadth	Thickness
Table top long edge	2	395	50	20
Table top short edge	2	245	50	20
Front Rails	2	<del>240</del> 390	60	18
Side Rails	2	<del>390</del> 240	60	18
Legs	4	430	45	45

Various machines are used to make the table.

- (b) Name the machines shown below.

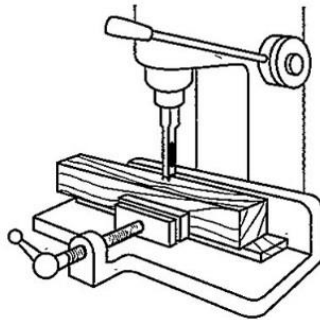

(i) mortice machine 1

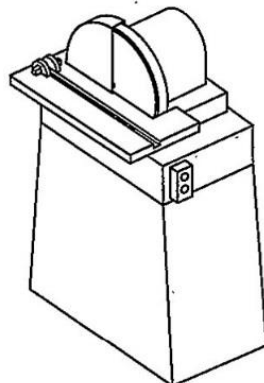

(ii) belt sander 1

**MARKS** DO NOT WRITE IN THIS MARGIN

2. (continued)

The table top has glass inserted, as shown below.

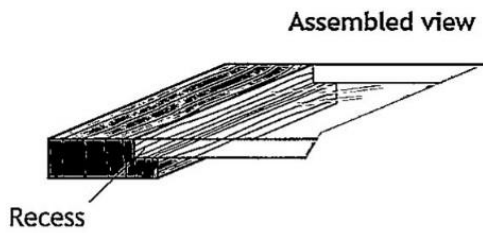
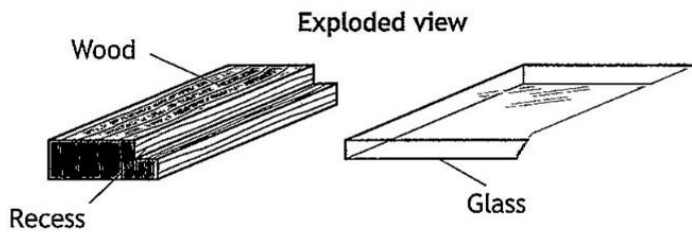
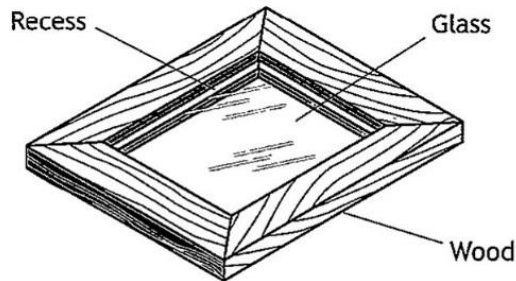

The hand tool shown below is used to cut the recess.

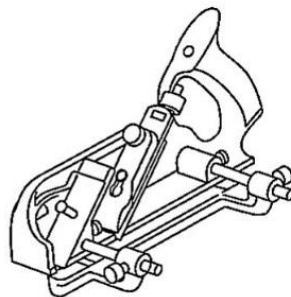

(c) Name this tool.

1

\_\_\_\_\_ *plough plane* \_\_\_\_\_



MARKS  
DO NOT  
WRITE IN  
THIS  
MARGIN

2. (continued)

The tool shown below is used during the assembly of the table top.

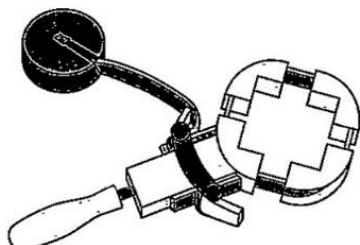

(d) Name this tool.

1

rubber band

Before final assembly, the table top is dry cramped.

(e) Explain the purpose of dry cramping.

1

To ensure there are no gaps and the wood is  
secure and fits before gluing.

Glue is used to assemble the table.

(f) State the name of a wood glue.

1

PVA

Before a finish is applied to the table it is prepared using different grades of glass paper: fine, medium and coarse.

(g) State which grade of glass paper is used first.

1

\_\_\_\_\_

(h) Explain the purpose of wetting the wood before starting the final stage of sanding.

1

Water makes the wood go firmer

\_\_\_\_\_

[Turn over

**MARKS** | DO NOT  
WRITE IN  
THIS  
MARGIN

3. A wooden tealight holder is shown below.

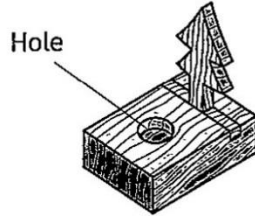

The diagrams below show the machine and forstner bit used to cut the hole in the tealight holder.

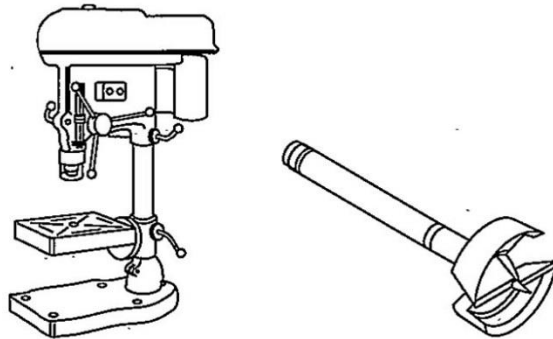

(a) (i) Name this machine.

1

Pillar drill

(ii) Explain why the forstner bit, shown above, was used to create the hole.

1

To create a larger hole.

\_\_\_\_\_  
\_\_\_\_\_

MARKS

DO NOT  
WRITE IN  
THIS  
MARGIN

## 3. (continued)

Health and safety is a priority when using the machine shown opposite.

- (b) Describe three health and safety checks that would be carried out on the machine before switching it on.

3

1 making sure the safety guard is down

2 The drill is ~~not~~ secure in the machine  
and ~~it~~ is not loose.

3 Your wood is cramped in position ready to  
be drilled.

[Turn over

**MARKS** DO NOT WRITE IN THIS MARGIN

3. (continued)

The tealight holder is joined, as shown below.

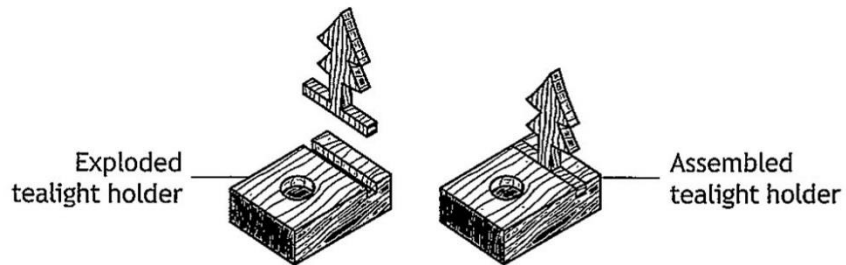

(c) Name this joint.

1

stopped housing.

MARKS  
DO NOT  
WRITE IN  
THIS  
MARGIN

3. (continued)

Diagram A shows the marked out joint used in the tealight holder. Diagram B shows the wood that is removed.

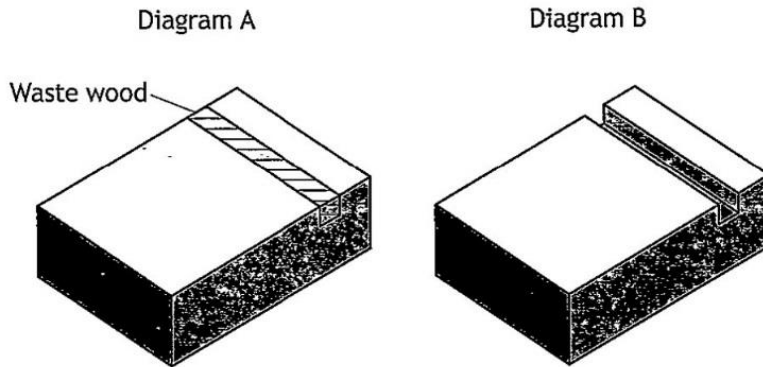

(d) Describe three stages in cutting and removing the wood from the joint shown above. You may use sketches to support your answer.

3

<p>Stage 1</p> <p>using a steel rule draw a line. using the correct width.</p>
<p>Stage 2</p> <p>using a marking gauge measure the depth going down</p>
<p>Stage 3</p> <p>using a tenon saw cut down and then using a mortice chisel and a mallet get rid of waste wood millimetre at a time.</p>

MARKS  
DO NOT  
WRITE IN  
THIS  
MARGIN

3. (continued)

The tealight holder, shown below, is manufactured using various hand tools.



(e) Name the tools shown below and describe what they are used for.

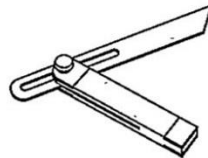

(i) Name

1

try-square

(ii) Use

1

to measure 180° angles in wood or any other angle.

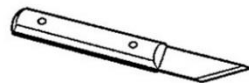

(iii) Name

1

chisel

(iv) Use

1

chisel out waste wood.

MARKS

DO NOT  
WRITE IN  
THIS  
MARGIN

## 3. (continued)

- (f) Explain the purpose of the brass back on the tenon saw shown below.

1

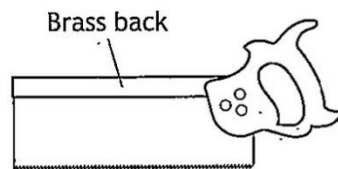

so that the blade does not bend or break  
and gives a straighter cut.

[Turn over

4. A wooden bowl is shown below.

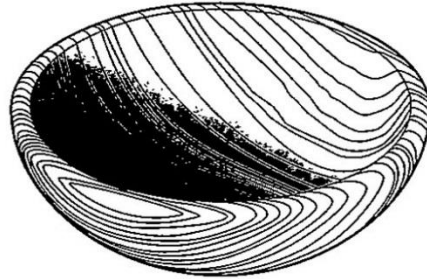

The bowl is made from one piece of material called a blank, shown below.

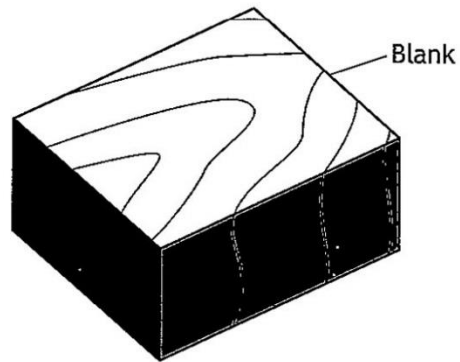

The blank has to be prepared for the turning process before it is mounted on the woodturning lathe.

DO NOT  
WRITE IN  
THIS  
MARGIN



MARKS  
DO NOT  
WRITE IN  
THIS  
MARGIN

## 4. (continued)

- (a) Describe two stages in the process of marking out the blank.

You may use sketches to support your answer.

The stages must be in the correct order.

2

Stage 1

using a compass mark out the  
circumference

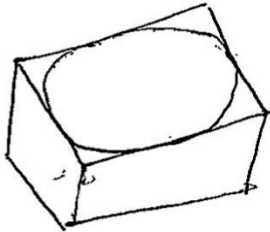

Stage 2

use a smoothing plane to ~~curve~~ curve  
the corners

[Turn over

MARKS  
DO NOT WRITE IN THIS MARGIN

4. (continued)

In preparing the top surface of the wooden blank before marking it out, a smoothing plane is used.

A diagram of the smoothing plane is shown below.

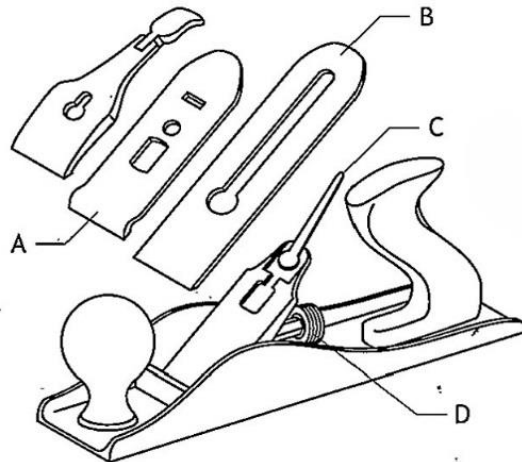

(b) Name parts A, B, C and D of the smoothing plane.

4

A soleplate

B \_\_\_\_\_

C blade

D turning screw

The attachment for mounting the bowl on the woodturning lathe is shown below.

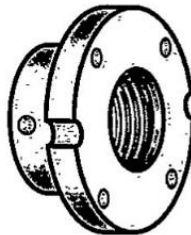

(c) Name this attachment.

1

turning screw

MARKS DO NOT  
WRITE IN  
THIS  
MARGIN

4. (continued)

The attachment is mounted onto the woodturning lathe shown below.

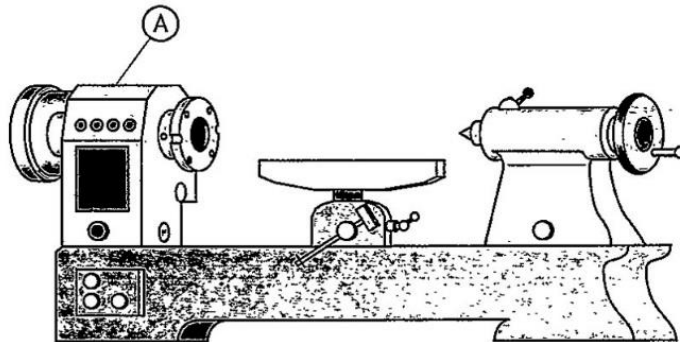

(d) Name part A shown above.

1

\_\_\_\_\_

The tools shown are used to help shape the bowl on the woodturning lathe.

(e) Name the tools shown below.

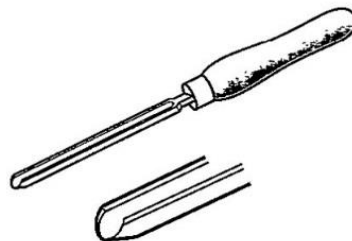

(i) The rounder

1

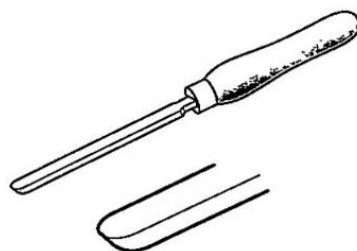

(ii) the scraper.

1

[Turn over

**MARKS** DO NOT WRITE IN THIS MARGIN

**4. (continued)**

When shaping wood on the woodturning lathe it is important for safety reasons to have the cutting tool at the correct height.

(f) Identify the correct tool height by ticking **one** of the boxes below.

**1**

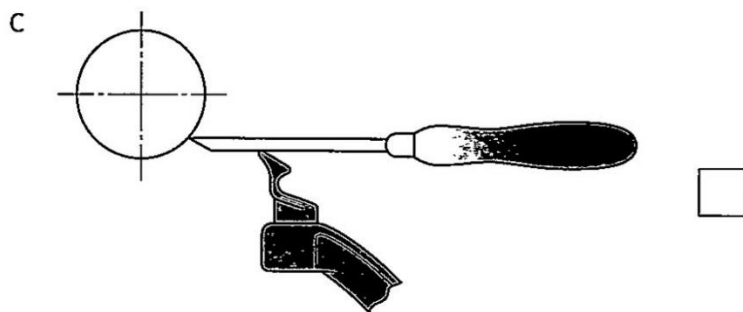
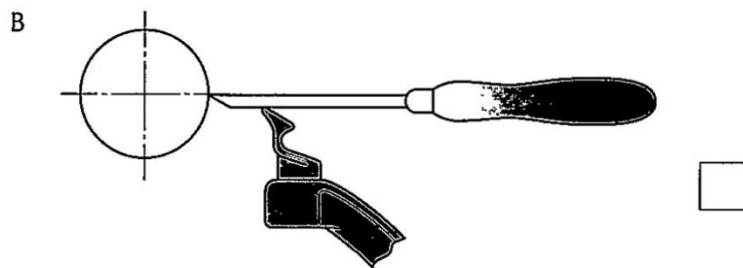
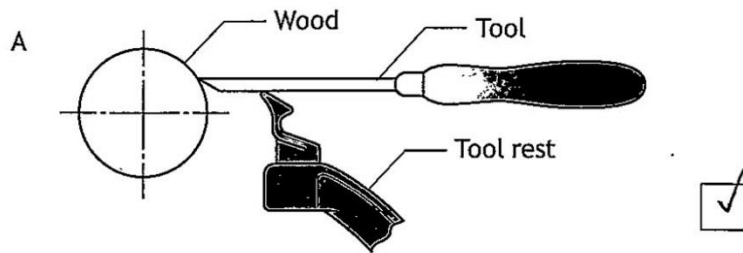

MARKS  
DO NOT  
WRITE IN  
THIS  
MARGIN

4. (continued)

A varnish finish is to be applied to the bowl. The bowl is prepared for varnishing while still on the woodturning lathe.

(g) Describe three actions that will ensure a good quality surface finish is achieved before applying the varnish.

3

1 Wet the wood.

\_\_\_\_\_

\_\_\_\_\_

2 sand out any rough bits.

\_\_\_\_\_

\_\_\_\_\_

3 \_\_\_\_\_

\_\_\_\_\_

\_\_\_\_\_

Health and safety in a workshop is a priority.

(h) Describe three personal safety precautions you would take before switching on the woodturning lathe.

3

1 check that the tool rest is in position  
and secure

2 the extractor fan is on

\_\_\_\_\_

\_\_\_\_\_

3 \_\_\_\_\_

\_\_\_\_\_

\_\_\_\_\_

## 4. (continued)

The bowl is made from wood left over from another project.

- (i) Explain the reason why this is environmentally friendly.

MARKS | DO NOT  
WRITE IN  
THIS  
MARGIN

1

~~Reason~~ Less trees being cut down  
allowing animals who have habitats in them  
to stay there.

[END OF QUESTION PAPER]