

Candidate 4 evidence

SECTION 1 — MULTIPLE CHOICE — 10 marks

Attempt ALL questions

Tick (✓) one box in each question.

1. Which camera control does not affect exposure? 1

- Aperture
- White balance
- ISO
- Shutter speed

2. Which type of image is represented by this histogram? 1



- Black point
- Low key
- Over-exposed
- High contrast

3. What affects the resolution of a digital image? 1

- Auto-bracketing
- EV number
- White balance
- Pixels per inch

4. Which image was taken using the lowest f-number setting?

1



5. Shutter speed is measured in seconds.
Which shutter speed setting is slowest?

1

 5 1/30 1/250 2

6. The photographer made an adjustment to one camera control after taking Image 1, which resulted in Image 2.



Image 1



Image 2

Which statement is correct?

1

- The ISO has been adjusted from ISO 100 to ISO 400
- The shutter speed has been adjusted from 1 second to 1/125 second
- The f-number has been adjusted from f11 to f22
- The white balance has been adjusted from daylight to cloudy

7. When macro pre-set mode is selected on a DSLR camera, which setting is automatically adjusted?

1

- Aperture
- Auto-bracketing
- ISO
- Shutter speed

8. Which white balance setting is indicated by the position of the arrow?

1



- Fluorescent
- Daylight
- Shade
- Tungsten

9. The photographer applied one post-production enhancement to Image 1, resulting in Image 2.



Image 1



Image 2

Which post-production enhancement did the photographer apply?

1

- Raised brightness
- Reduced saturation
- Increased contrast
- Lightened shadows

10. What does this diagram represent?

1

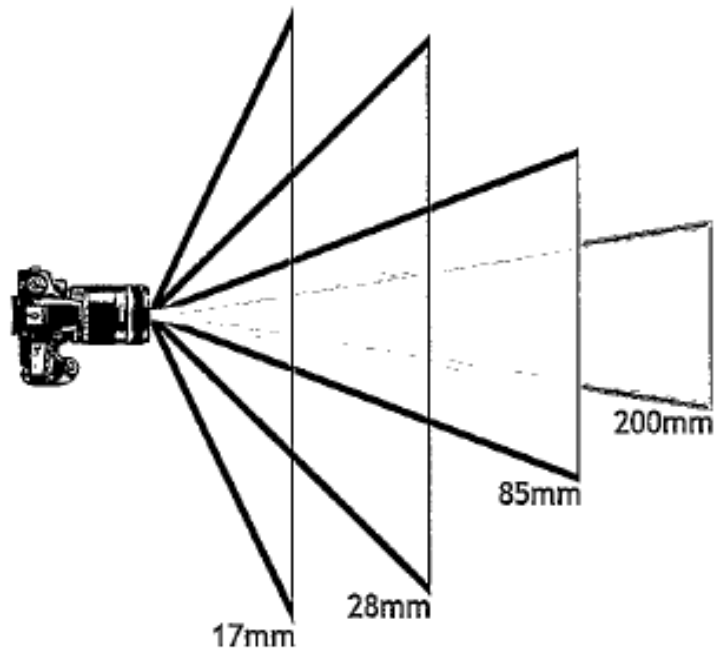

- Depth of field
- Colour cast
- Tonal range
- Focal length

SECTION 2 — ANALYSIS — 20 marks

Attempt BOTH questions



Untitled #6 (2019) by Ian Howorth

Refer to this image on the supplementary sheet when answering question 11.

11. (a) Identify one camera control that the photographer could have used when capturing this image.

Explain the effect of the camera control on this image.

⊙
P14 F)
larger
aperture

2

Camera control Aperture

Explanation The photographer may have used a larger aperture to create a more shallow depth of field. This is evident as the salt and pepper in the background are blurry and out of focus. This draws more attention to the foreground.

11. (continued)

- (b) Explain the visual effect of the following two pieces of equipment on this image.

2

Equipment: standard lens

The photographer has used a standard lens to capture this image. This lens makes the photograph more relatable to viewers as it makes the image look as though we are seeing it through our own eyes. This allows the viewer to connect with the image more.

Equipment: neutral density filter

The photographer has used a neutral density filter to capture this image. This can be seen as the image appears more ^{and dense} matter. This filter makes the image appear more cozy and soft to the viewer.

11. (continued)

- (c) Explain how three visual elements have been used for creative effect in this image.

3

Visual element 1 Line

Explanation The photographer has used line ~~to~~ in this image. This can be seen in the frame of the window and the edge of the table. These straight lines lead the viewer's eye all around the image and allows them to take in the whole image.

Visual element 2 Colour

Explanation The photographer has used ^{Contrasting} colours in this image. This is evident through the cool and dark window frame and environment outside which contrasts the warm oranges and yellows of the chair and clips on the table. This effect draws more attention to the focal points of the image like the chair, and draws the viewer's eye towards it.

Visual element 3 Texture

Explanation The photographer has used texture in this image. This can be seen in the smooth, shiny and reflective surface of the window glass and the soft and squishy texture of the chair. This draws further attention towards the chair as it contrasts the smooth, shininess of the glass, further emphasizing it as a focal point.

11. (continued)

- (d) Explain how the photographer has used symbolism to communicate a message in this image.

3

The photographer has used symbolism in this image^{possibly} by choosing the subject matter of dirty plates and unwashed glasses. This may convey to the viewer that people had purposefully left their own mess on a restaurant table as they simply expect someone else to clean it up for them^{without a word.} This message could make the viewer feel guilt, and could^{also} relate to them personally as they may feel they have experienced something similar.



⑥
f/14

What Are You Looking At? (2016) by Richard Morgan

Refer to this image on the supplementary sheet when answering question 12.

12. Discuss the technical and creative factors which the photographer could have considered when creating this image.

10

- ① The photographer has used a small aperture to capture this image. This is evident as the entire image is clear and in focus with a deep depth of field. This effect makes the image ^{more} visually interesting for the viewer.
- ② The photographer has used a fast shutter speed to capture this image. This is evident as the image is completely clear even in the presence of motion. This makes the image appear as though it is frozen in time, and prevents any motion blur.

12. (continued)

③ The photographer has used leading lines in this image. This is evident through the vertical lines in the building on the top of the image. These lines lead the viewer's eyes down the image and direct them to the large crowd of people, emphasizing them and drawing more attention to them.

④ The photographer has used tone in this image. This is evident as many of the figures in this image are wearing lighter clothes and are therefore a lighter tone however the man in the foreground who stares at the photographer is wearing darker clothes. This helps emphasize him as a focal point as it draws your eyes towards him.

⑤ The photographer has used contrast in this image. This can be seen as all of the subjects in this image are staring and pointing at a particular point of interest not seen in the image, however the man in the foreground is looking directly into the camera and at the viewer. This immediately draws the viewer's eyes towards this man, emphasizing him as a focal point.

12. (continued)

- ⑥ The photographer may have used a standard lens to capture this image. This is evident as the image appears as though you are looking at ~~it~~ ^{the scene} with your own eyes. This could make the viewer relate to the image more and make it feel like the viewer is actually there.
- ⑦ The photographer ~~was~~ ^{may have} used a triangular composition in this image. This can be seen from the rim of the beer glass up to the face of the man staring at the camera back down ^{to} the right corner of the table. This leads the viewer's eye all around the focal point of the man further emphasising him.
- ⑧ The photographer has used ~~shape~~ ^{shape/form} in this image. This can be seen from the organic and unique shapes of the people and figures in contrast to the rigid, straight and manmade ~~or~~ rectangles of the buildings. This contrasts each other and further emphasises ~~a~~ the people and figures.

12. (continued)

⑨ The photographer has used texture in this image. This can be seen in the smooth wooden surface of the table and the ^{soft} fabric of the clothes on the people. This contrast emphasizes the wooden table and makes it stand out amongst the cloth.

⑩ The photographer has chosen to make this image black and white or greyscale. This ~~is~~ post-production edit could of been used to make the image feel more dramatic and serious, and could make the viewer feel that the image ~~is~~ should be viewed seriously.