

Candidate 2 evidence

SECTION 1 — MULTIPLE CHOICE — 10 marks

Attempt ALL questions

Tick (✓) one box in each question.

1. Which camera control does not affect exposure? 1

- Aperture
- White balance
- ISO
- Shutter speed

2. Which type of image is represented by this histogram? 1



- Black point
- Low key
- Over-exposed
- High contrast

3. What affects the resolution of a digital image? 1

- Auto-bracketing
- EV number
- White balance
- Pixels per inch

4. Which image was taken using the lowest f-number setting?

1



5. Shutter speed is measured in seconds.
Which shutter speed setting is slowest?

1

 5 1/30 1/250 2

6. The photographer made an adjustment to one camera control after taking Image 1, which resulted in Image 2.



Image 1

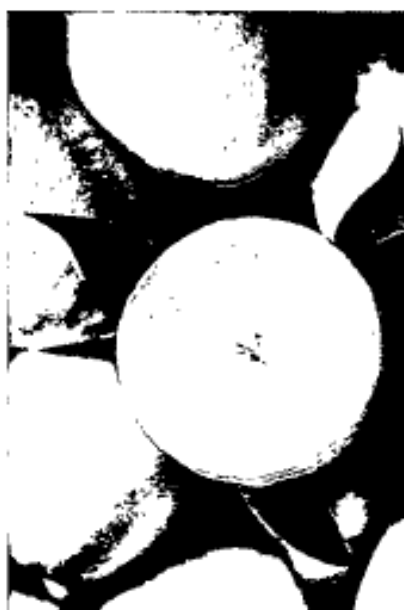

Image 2

Which statement is correct?

1

- The ISO has been adjusted from ISO 100 to ISO 400
- The shutter speed has been adjusted from 1 second to 1/125 second
- The f-number has been adjusted from f11 to f22
- The white balance has been adjusted from daylight to cloudy

7. When macro pre-set mode is selected on a DSLR camera, which setting is automatically adjusted?

1

- Aperture
- Auto-bracketing
- ISO
- Shutter speed

8. Which white balance setting is indicated by the position of the arrow?

1

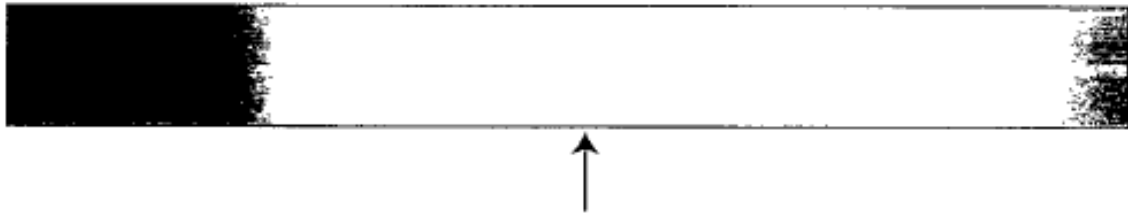

- Fluorescent
- Daylight
- Shade
- Tungsten

9. The photographer applied one post-production enhancement to Image 1, resulting in Image 2.



Image 1



Image 2

Which post-production enhancement did the photographer apply?

1

- Raised brightness
- Reduced saturation
- Increased contrast
- Lightened shadows

10. What does this diagram represent?

1

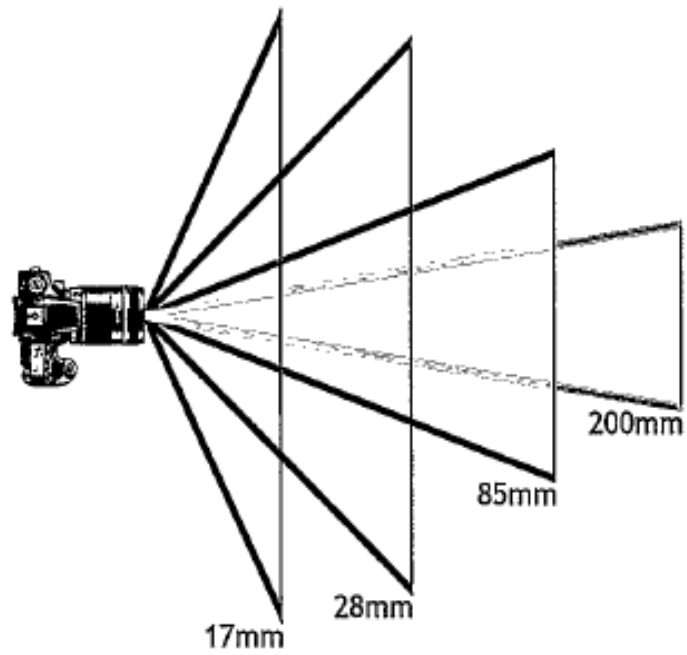

- Depth of field
- Colour cast
- Tonal range
- Focal length

SECTION 2 — ANALYSIS — 20 marks

Attempt BOTH questions

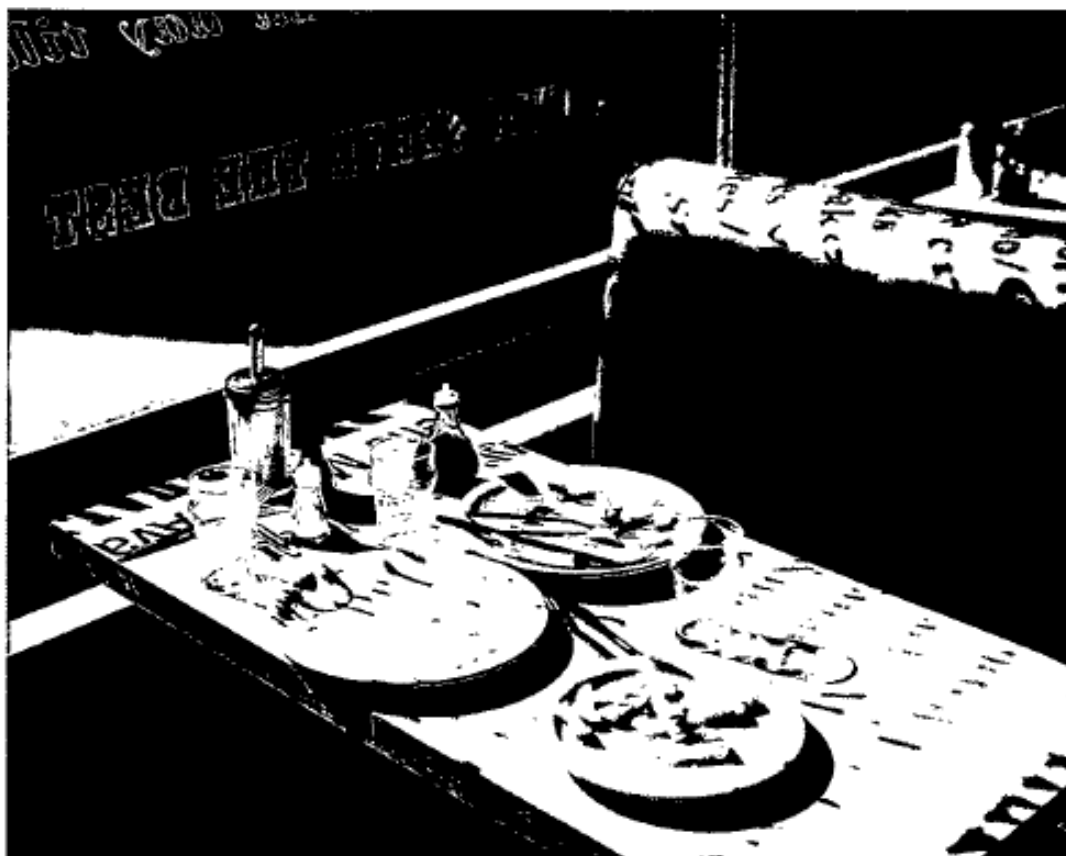

Untitled #6 (2019) by Ian Howorth

Refer to this image on the supplementary sheet when answering question 11.

11. (a) Identify one camera control that the photographer could have used when capturing this image.

Explain the effect of the camera control on this image.

2

Camera control ~~Medium~~ ^{wide} aperture

Explanation ~~A medium~~ ^{slightly wide} aperture has been used to capture this image, this would ensure the main subjects of the plates table and ~~chairs~~ ^{bench} are in focus and blurs the table behind the ~~chair~~ ^{bench} and the pavement outside so ensuring the viewers attention is drawn to the foreground.

11. (continued)

- (b) Explain the visual effect of the following two pieces of equipment on this image.

2

Equipment: standard lens

A standard lens has a field of view that is similar to the human eye; this means the photo looks normal and appears natural to the viewers, this combined with the comforting subject matter of a restaurant will create a calming and welcoming mood and atmosphere.

Equipment: neutral density filter

A neutral density filter would have been used to capture this image as it will lower the exposure by one or more stops which allows the photographer to use a wider aperture to keep the focus on the plates and table, but also allow them to capture the bright sun with shadows without the image becoming overexposed.

11. (continued)

- (c) Explain how three visual elements have been used for creative effect in this image.

3

Visual element 1 Shape

Explanation A Triangular composition has been created with the use of the white ~~table and plates~~ ^{plates, this draws} ~~and~~ ~~plates~~ ~~and~~ the viewers eye around the important Subject matter and ~~the~~ ^{this} geometric ^{triangle} shape created with the ^{geometric} ~~circles~~ ^{plates} has visual impact and makes the plates of food the focal point.

Visual element 2 Tone

Explanation light white tones can be seen in the tables and the top of the bench and window writing this has contrast to the dark black tones of the shadows under the table and on the pavement, this contrast creates a dramatic photo and creates visual impact.

Visual element 3 ~~colour~~ ~~text~~ line

Explanation The ^{rapher} photographer has used a ^{diagonal} ~~horizontal~~ leading line with the bottom of the window, it covers the whole length of the ^{image} ~~image~~ which draws the viewers eye to the foreground and makes the empty plates of food the focal point, and creates a dynamic composition.

11. (continued)

- (d) Explain how the photographer has used symbolism to communicate a message in this image.

3

The photographer has used ~~a~~ the subject matter of empty dishes at a restaurant, this suggests people have just eaten here and then left, this could send the message that they have enjoyed their meal and could resonate with the viewer as the restaurant is small and perhaps by ~~a~~ ^{the} Seaside as it's fish and chips that they were eating, the restaurant isn't fancy and the image wants to send a welcoming message that reminds the viewer of home. The daylight lighting has been captured, the sun is shining onto the table and ~~bench~~ ^{bench}, this symbolises happiness as it is good weather and could be sending the message that sharing a meal here, (as there is multiple plates) has brought ~~them~~ ^{the photographer} ~~them~~ ^{felt happiness in} joy/reminds the viewer of when they have this context. The colour of the bench and ~~typography~~ ^{text} on the window are quite old-fashioned and are reminiscent of a ~~diner~~ fish and chip/seaside restaurant, this could symbolise nostalgia as the scene brings to mind childhood outings for the viewer and sends the message of a welcoming seaside town.



What Are You Looking At? (2016) by Richard Morgan

Refer to this image on the supplementary sheet when answering question 12.

12. Discuss the technical and creative factors which the photographer could have considered when creating this image.

10

The photographer has chosen to make their image black and white in colour, this reminds the viewer of an older photograph, this combined with the modern subject matter of mobile phones & sends the message that advanced technology is a problem ^{for humanity} and it wasn't when phones didn't exist/ long ago.

The repeating pattern created with lots of people all holding up their phones creates a busy/chaotic composition & which over whelms the viewer and

12. (continued)

Creates a claustrophobic mood and atmosphere, ~~the~~ emphasizing the message that phones have taken over society.

The photographer has used a narrow aperture to ensure the whole scene is in focus, this allows the viewer to see the whole large crowd and shows the mass of people filming with their phones, and reminding the viewer to live in the moment and that not everything has to be filmed.

Black tones can be seen in the building, ~~the~~ pillar and table in the foreground, and in the clothing of the ^{crowd} ground, this means the dark tones are scattered throughout the image, which draws the viewer's eye around the scene and creates balance and an aesthetically pleasing image.

The photographer has filled the left and right side of the image with black, this creates a frame and makes the crowd the focal point.

The photographer has filled the frame with the crowd and buildings, which all have rough ~~or~~ interesting textures, there's not really any negative space/sky/smooth areas, this creates a ^{busy} chaotic composition which overwhelms the viewer and creates a ~~anxious~~ ^{busy chaotic} mood and atmosphere.

12. (continued)

A fast Shutter speed has been used to capture the moving crowd of people in sharp clarity. This ensures the photo is clear and makes a more aesthetically pleasing and visual impacting photo as the message is immediately clear.

The black and white striped pattern created in the pillars of the building fills what would otherwise be negative space in the background and makes a more visually interesting image.

The lady in the foreground sits on a point of interest and is all light in tone, this makes her the focal point and draws the viewers attention from here back ^{wards} to the crowd drawing attention to important subject matter.

A psychological leading line is created with the crowd's eyes looking towards something not in frame, this makes the viewer wonder what they're looking at and creates an interesting image/story.

The crowd are lined up in rows and this creates a leading line to the centre of the

12. (continued)

Image, this leading line starts with the man in the bottom left corner and draws the eye into the image.

The use of ^{strong} black and white tones throughout the image creates a high contrast photo and creates visual impact, black tones are in the pillar, building and ~~to~~ ^{clothing} of the crowd and white can be seen in the curtain, distant buildings and crowds faces.

Various patterns can be seen on the clothing of the crowd, the man's shirt in the bottom left corner and the man's checkered shirt on the right foreground, this adds visual interest and adds to the busy mood and atmosphere as these spaces would otherwise be simple.