

PLAN

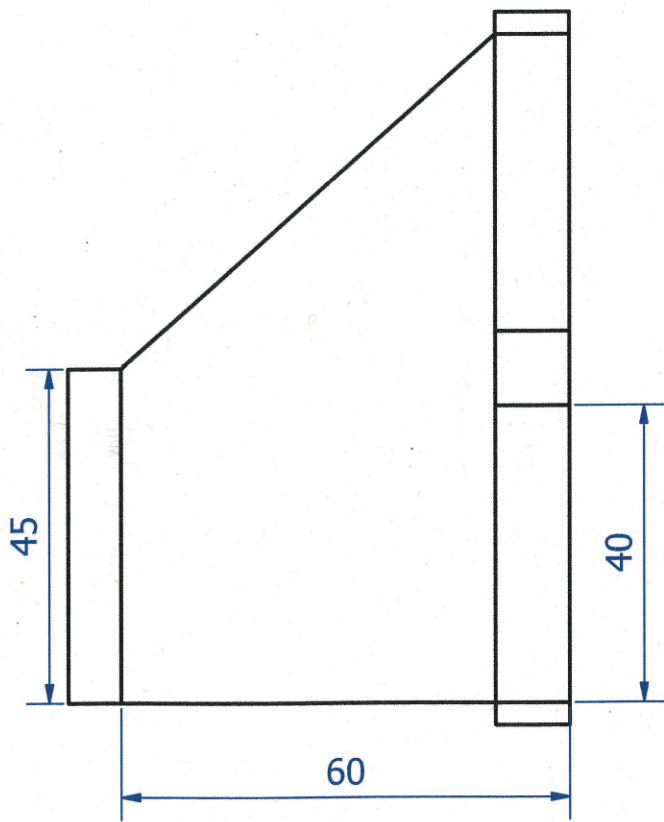

END ELEVATION

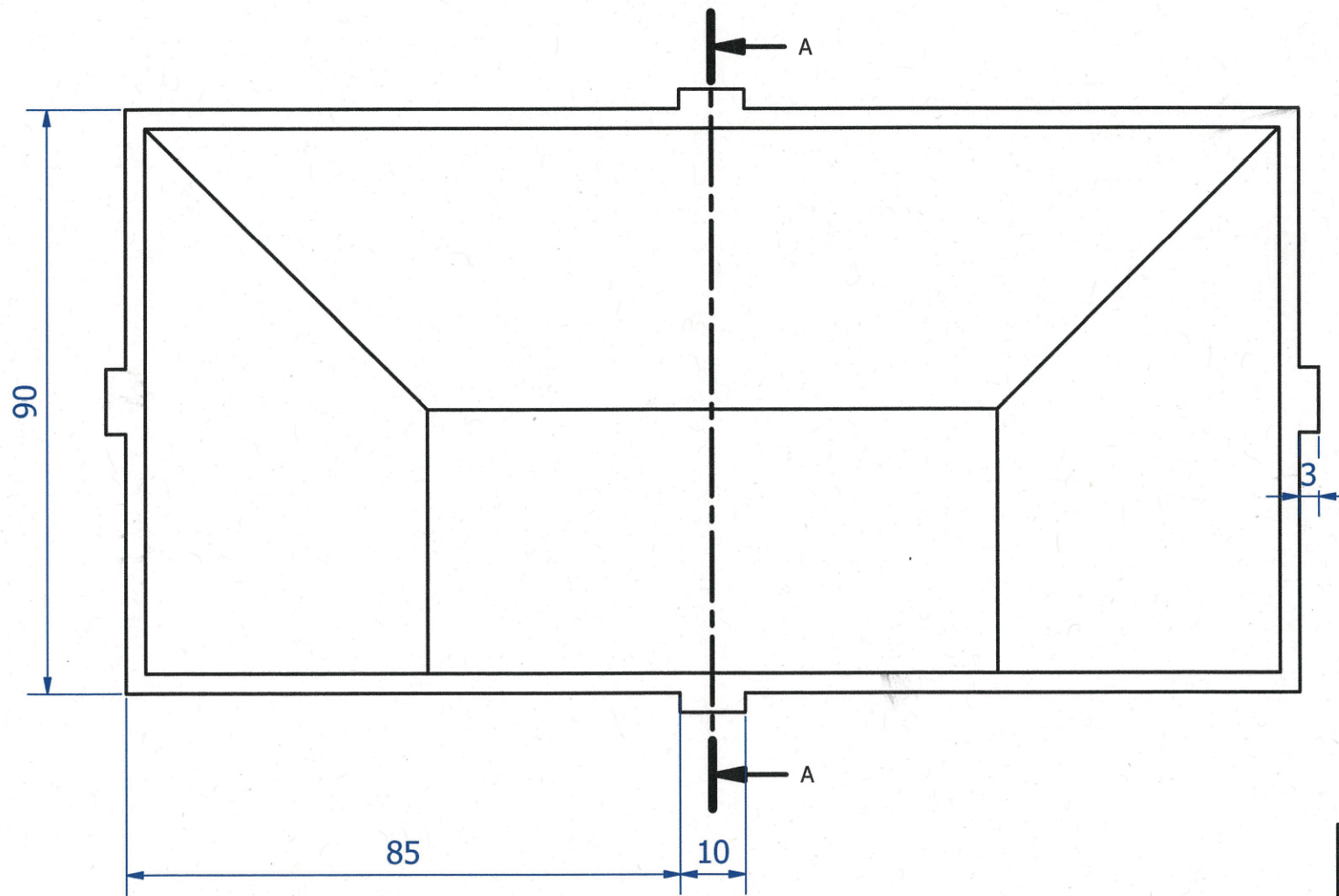

ELEVATION

AA(1:1)

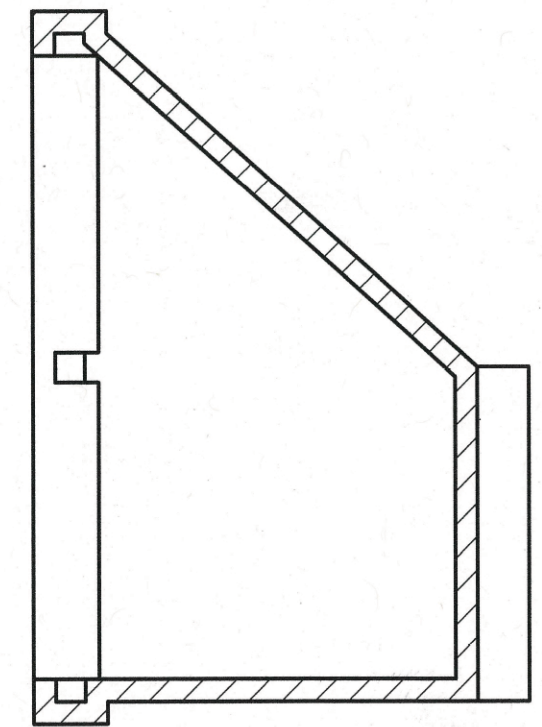

SECTIONAL END ELEVATION

Name		Title	1A i
Date	10/02/19		
Scale	1:1		

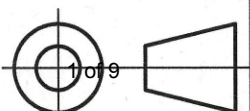

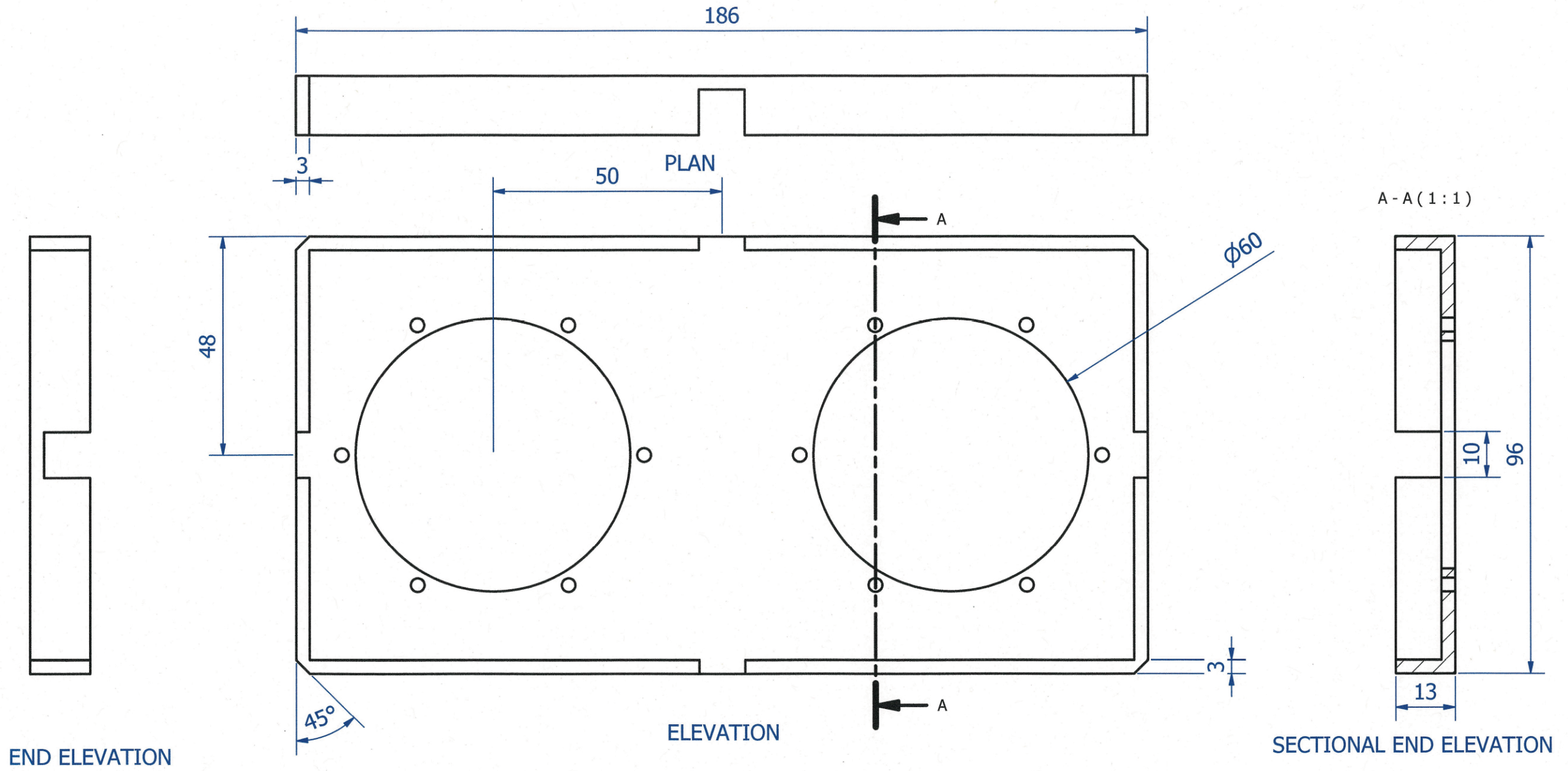

Name		Title	1AII
Date	12/02/19		
Scale	1:1		

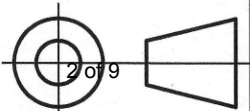

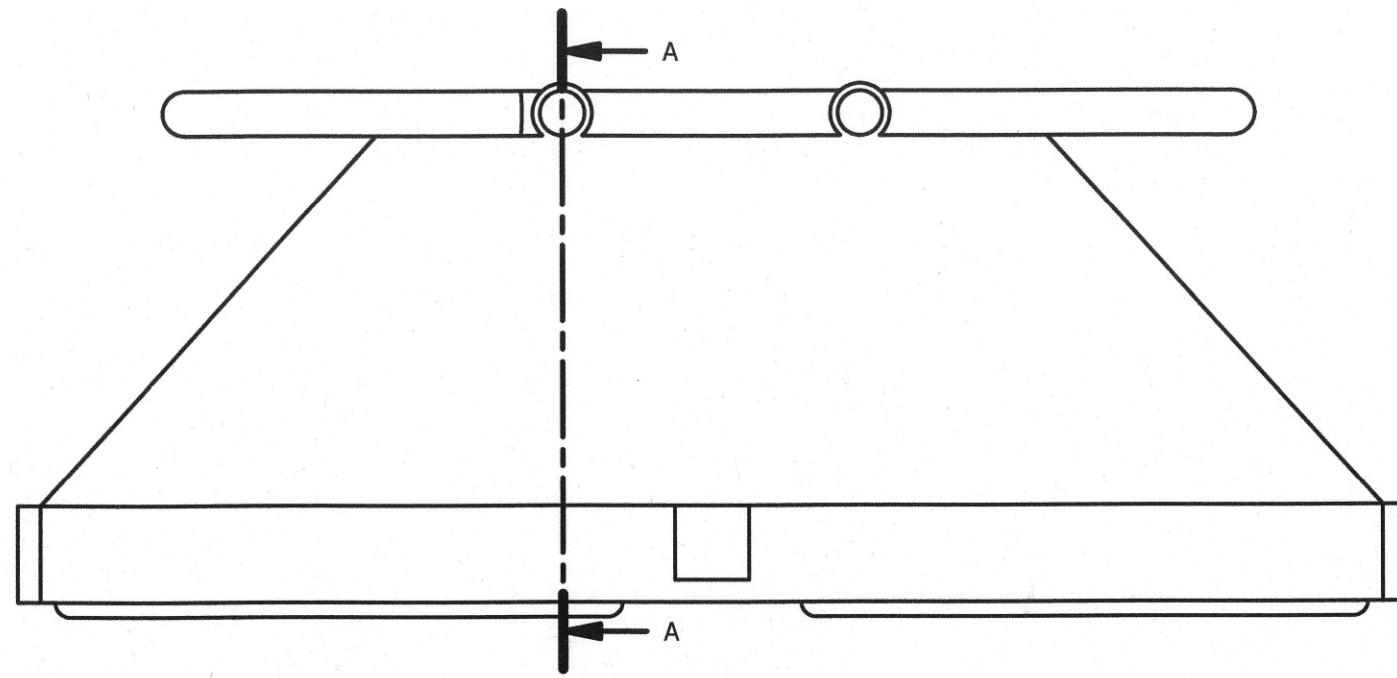

PLAN

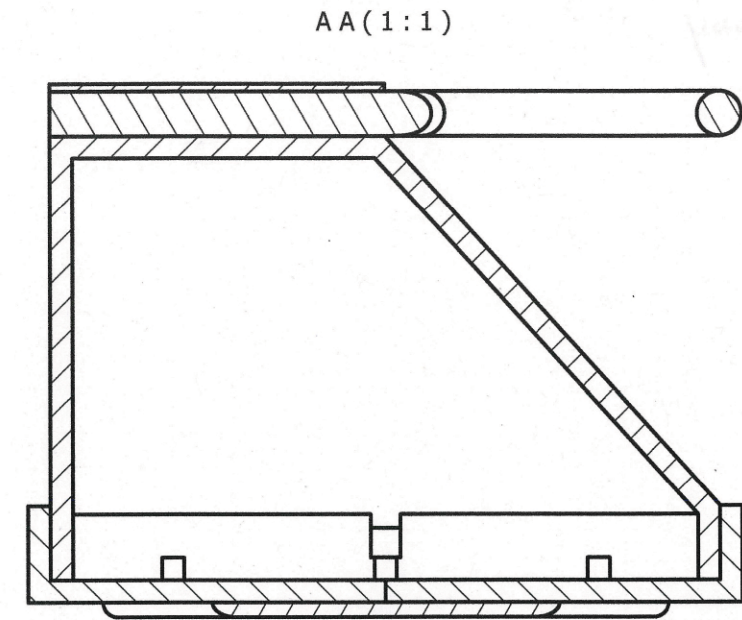

SECTIONAL END ELEVATION

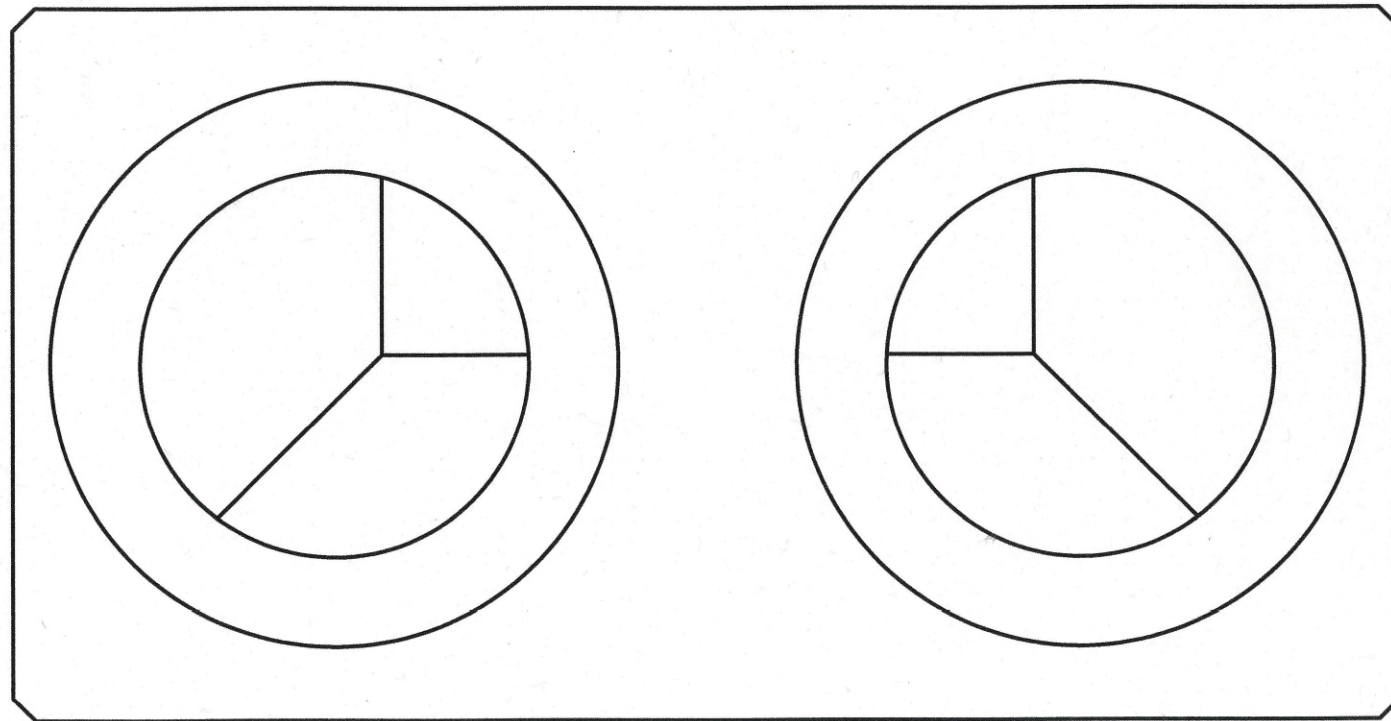

ELEVATION

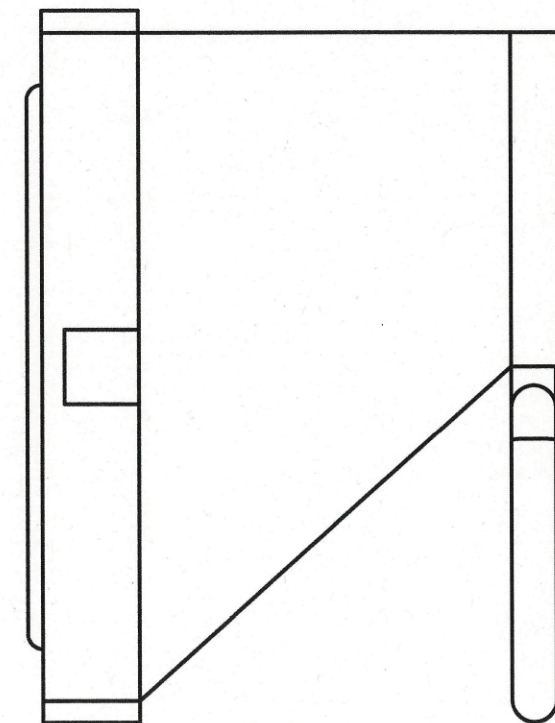

END ELEVATION

Name		Title	1b
Date	08/02/19		
Scale	1:1		

3 of 9

201055
199433
1404 1504
20F048

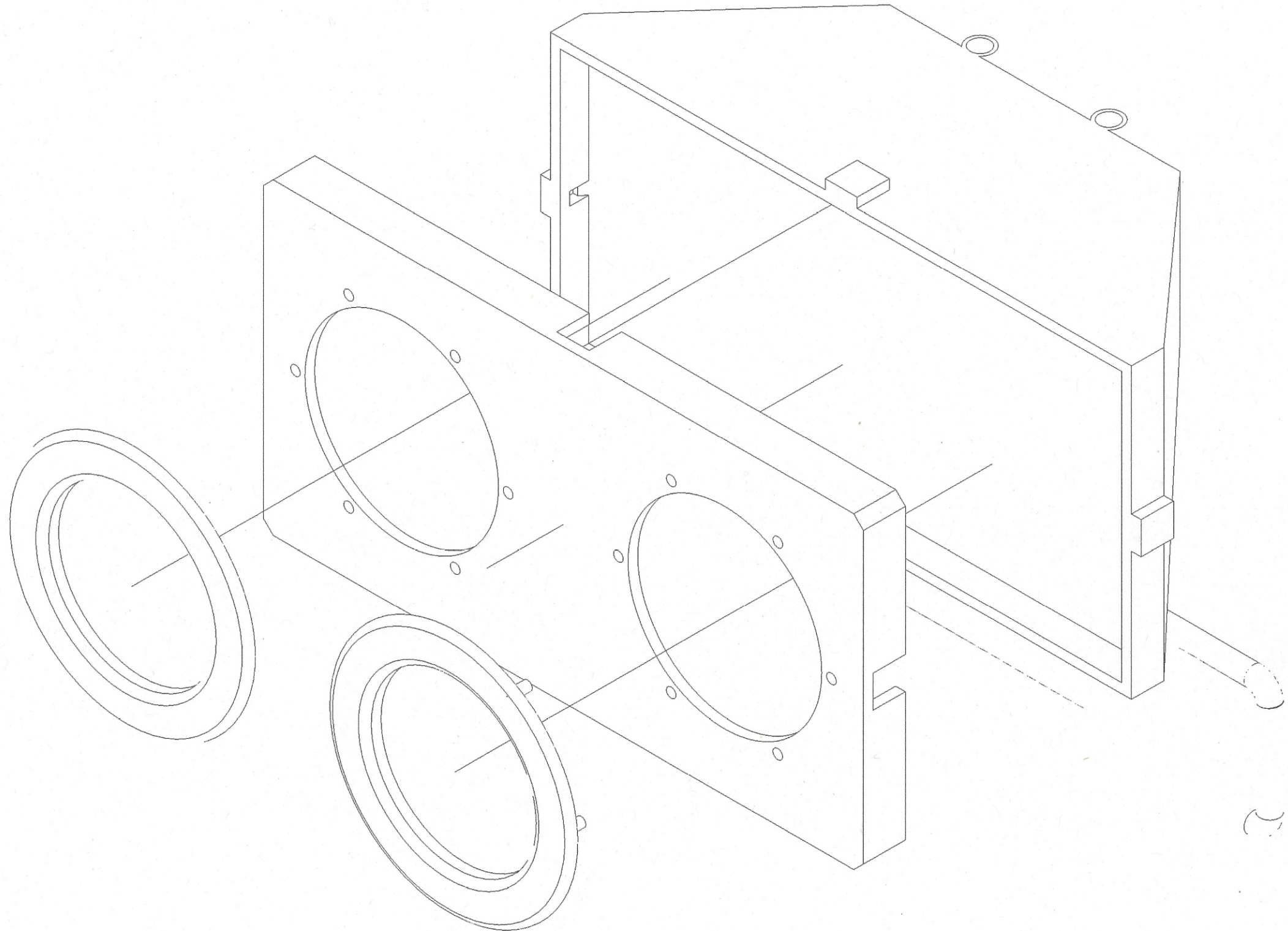

EXPLODED ISOMETRIC

Name		Title	1c/d
Date	10/02/19		
Scale	1:1		

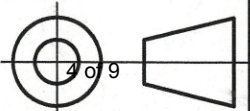

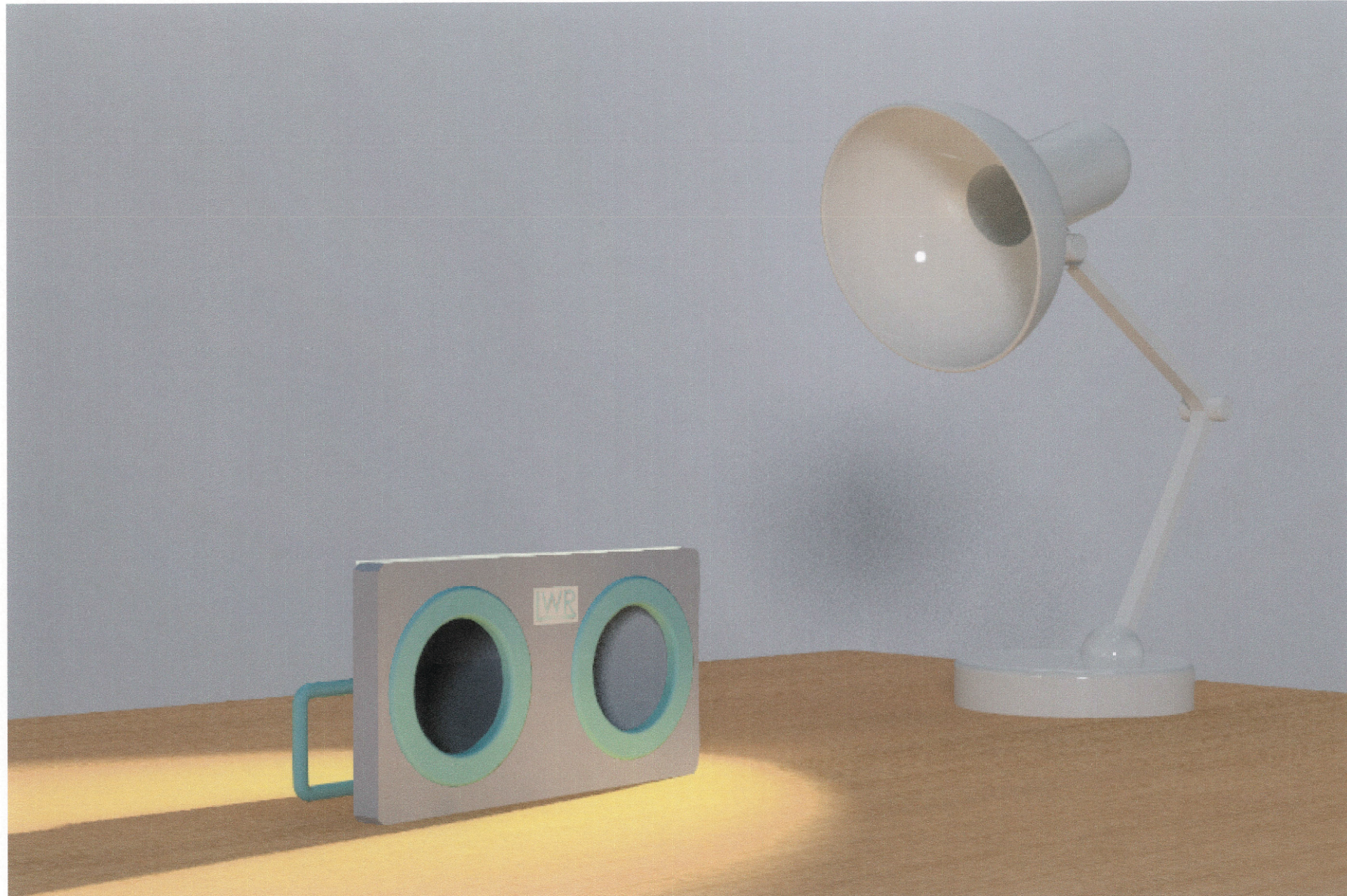

2A

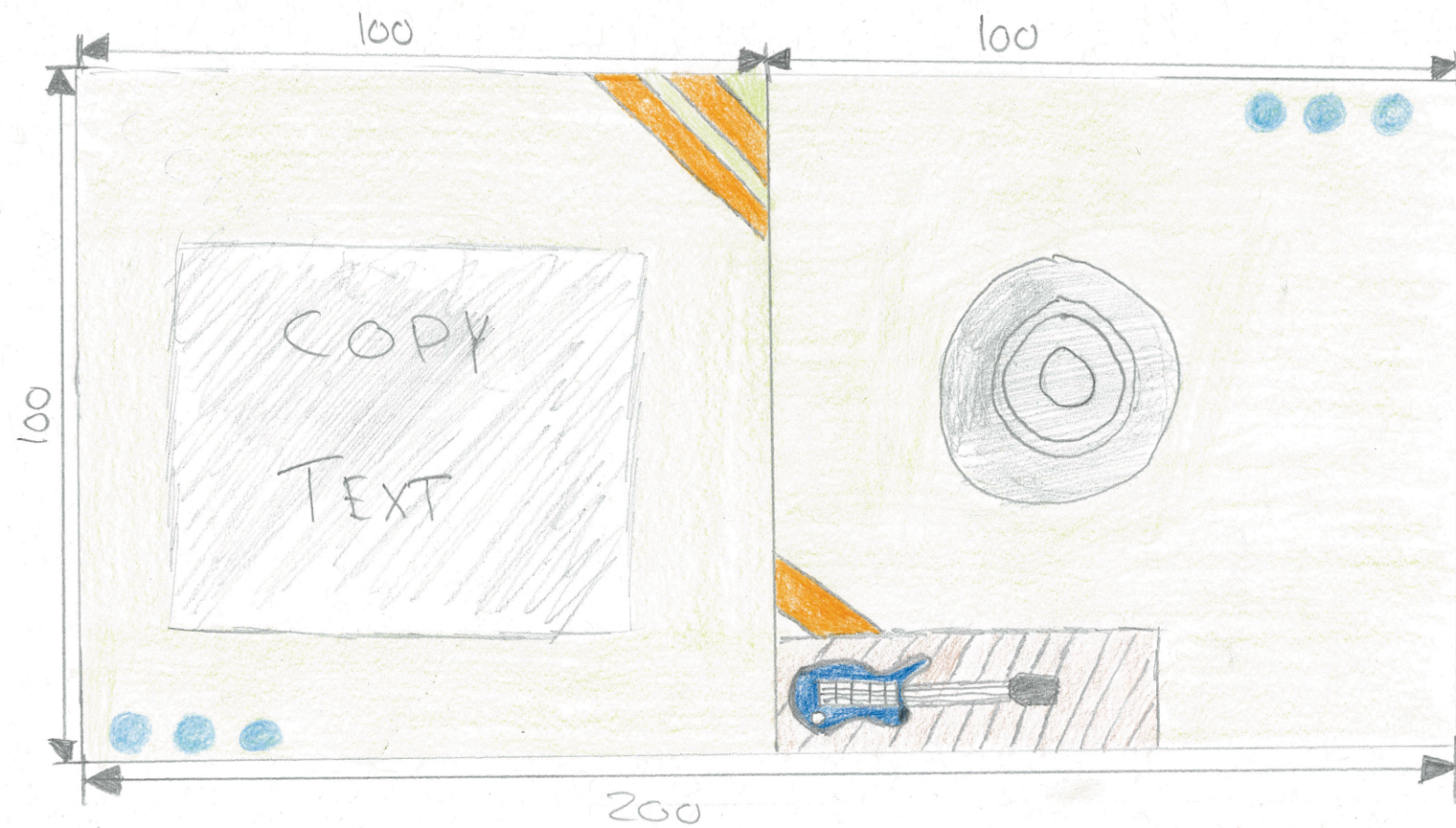
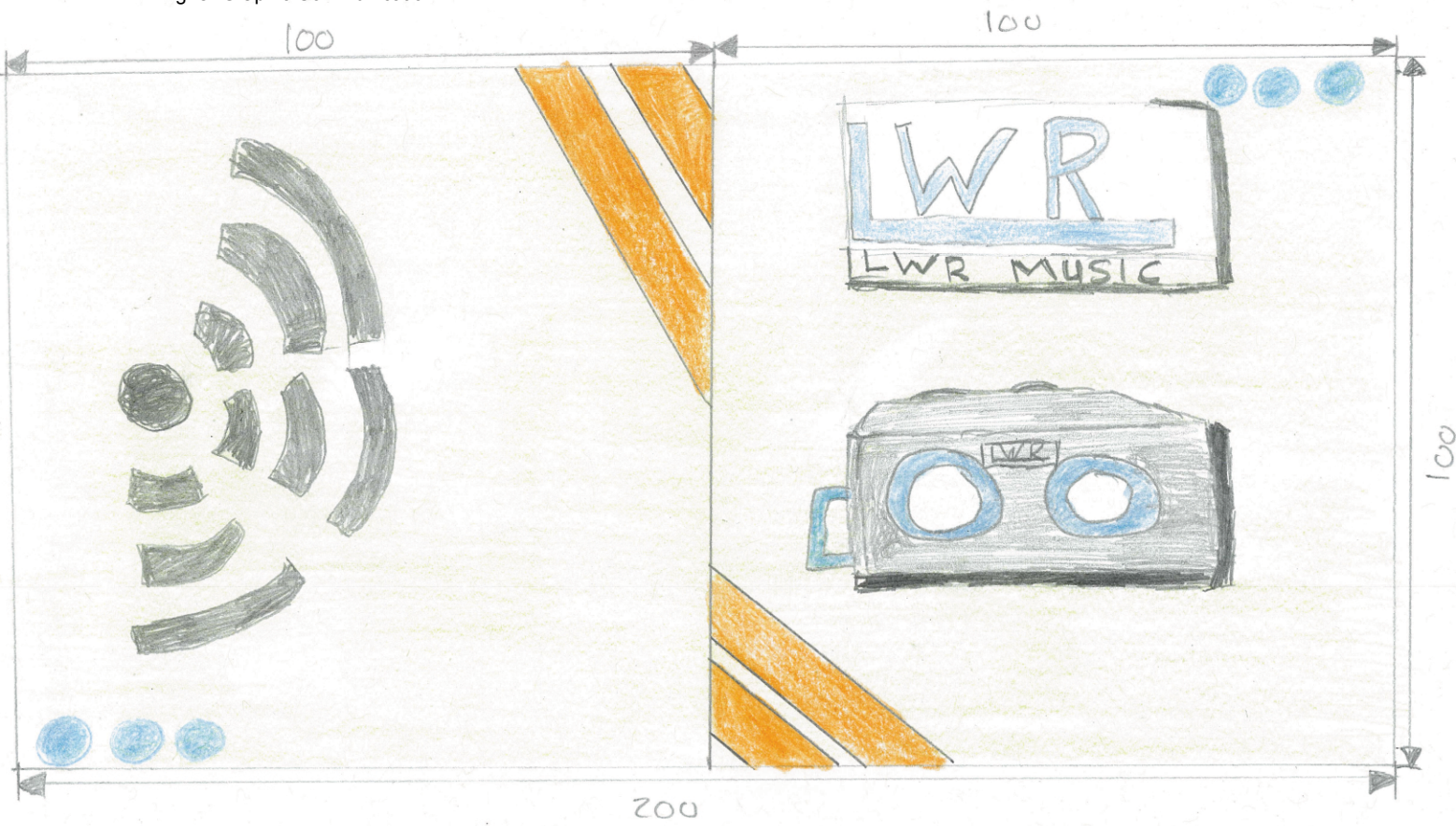

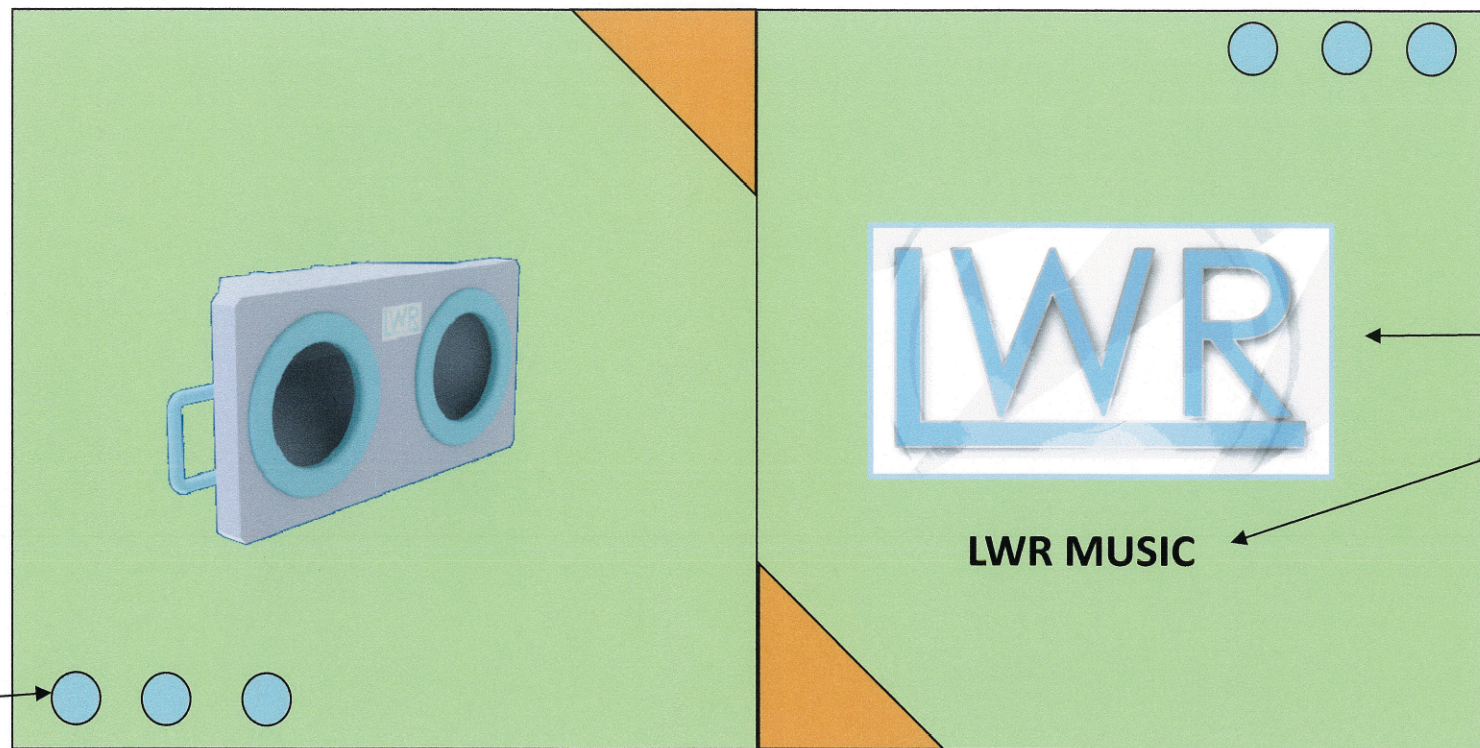

Logo and full name of company used in the design

Rhythm and company colours used. Rhythm is created by the repetition of the small blue circles throughout the design

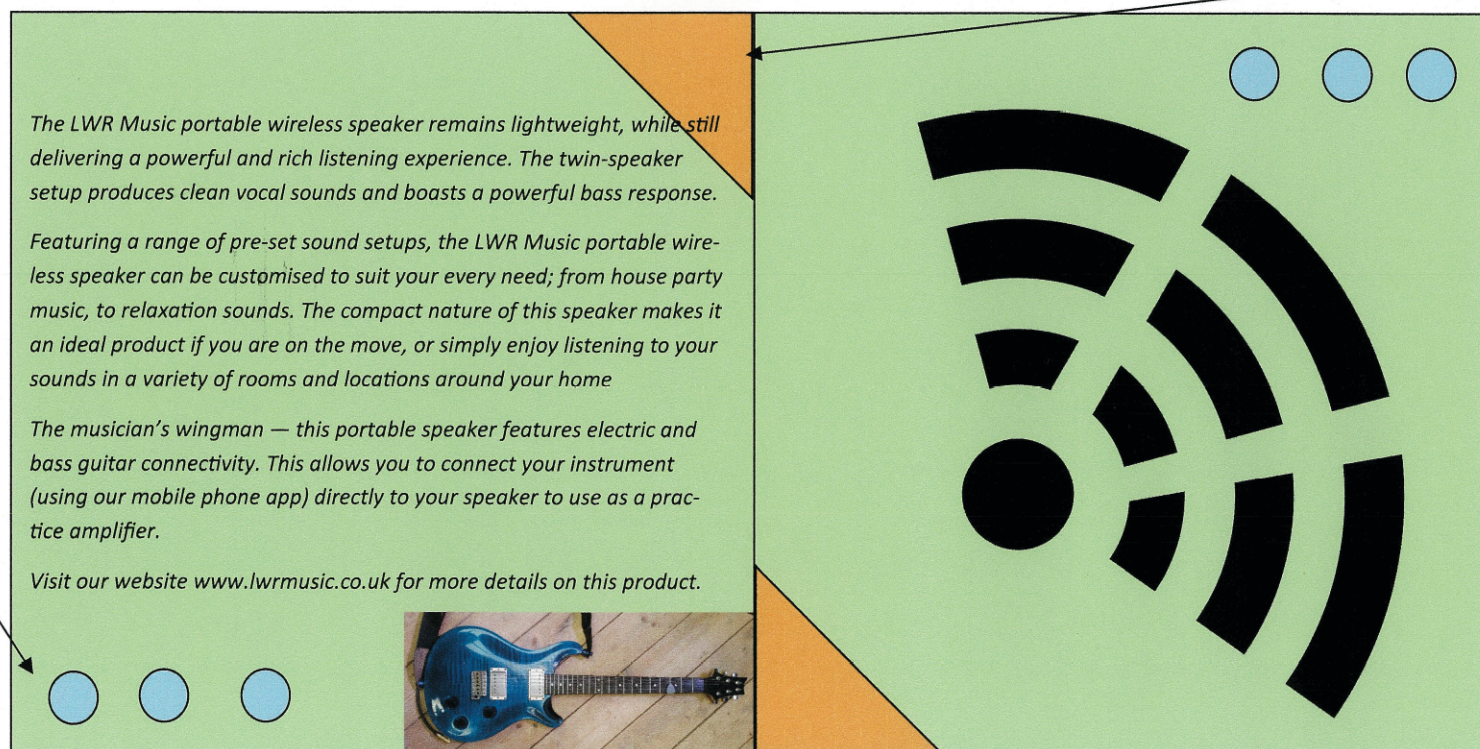

Depth created by overlapping the text over a feature in the design

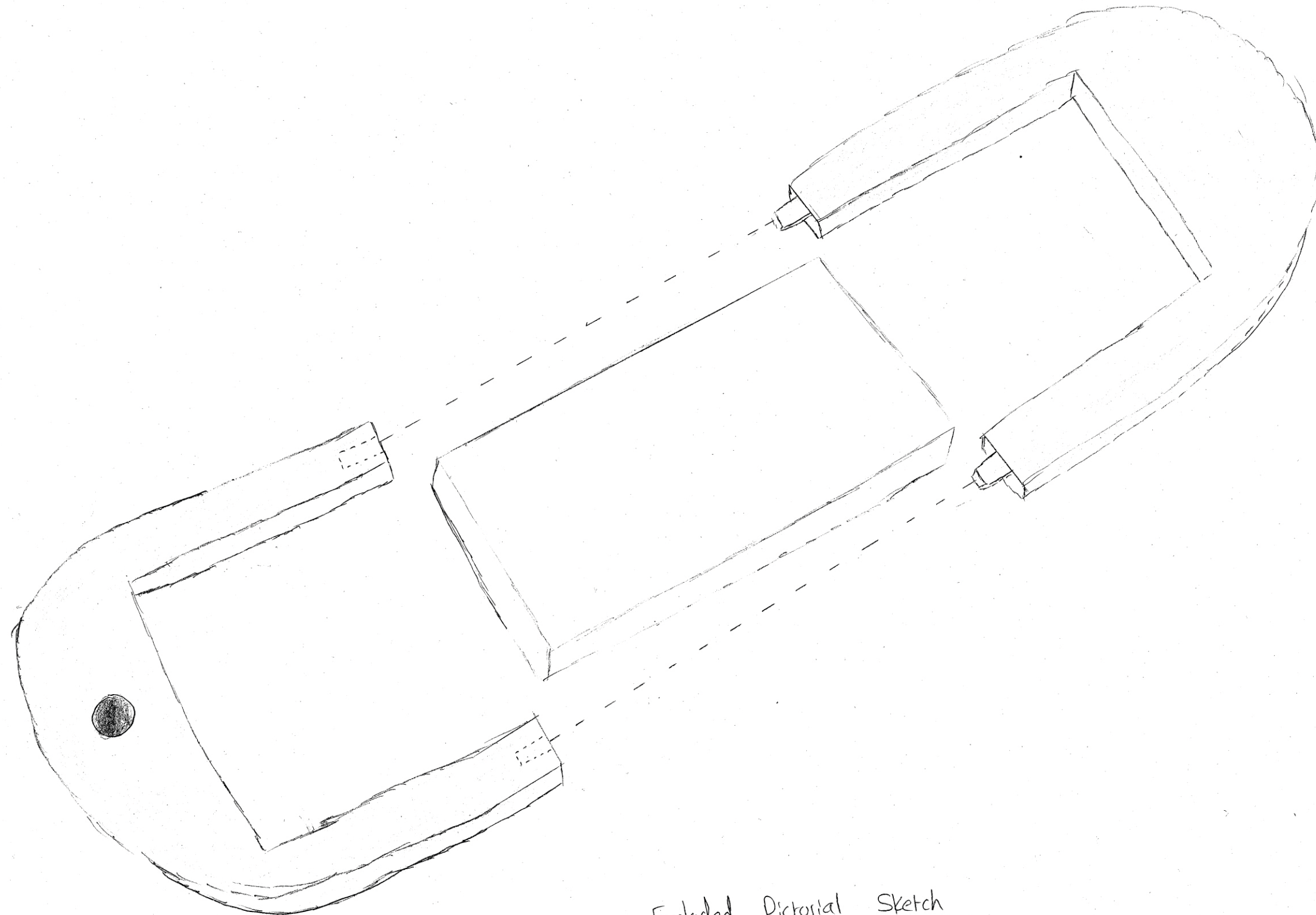

Exploded Pictorial Sketch

SIDE 1

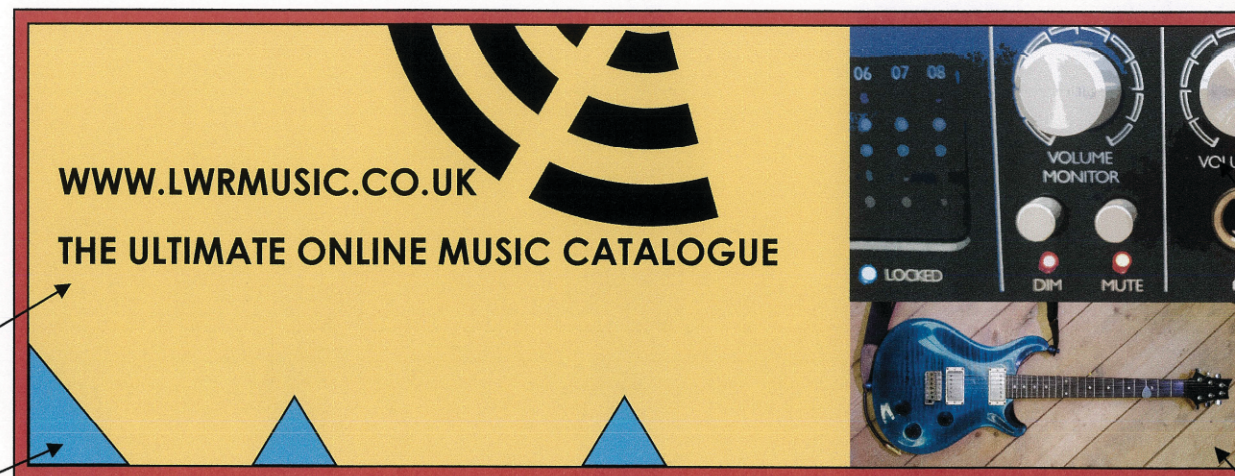

- Copy text, font style and allocated colours used in the design
- Colour fill used also in the design

- Bleed used on top right image to help make the layout more appealing
- Image from data sheet 8 present
- Drop shadow present behind assembled speaker, creates depth.

SIDE 2

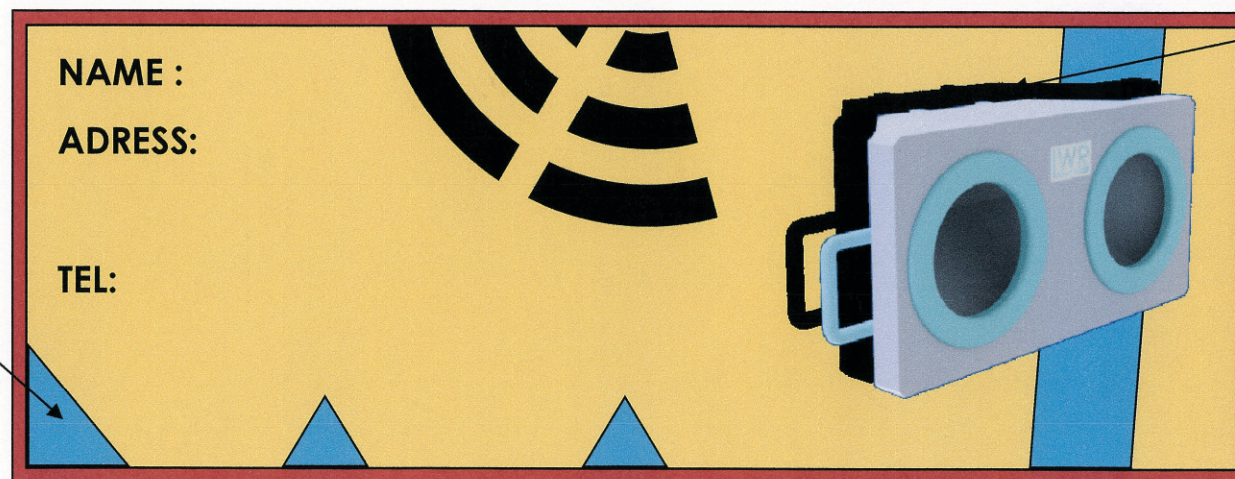

3B