

Task Lai

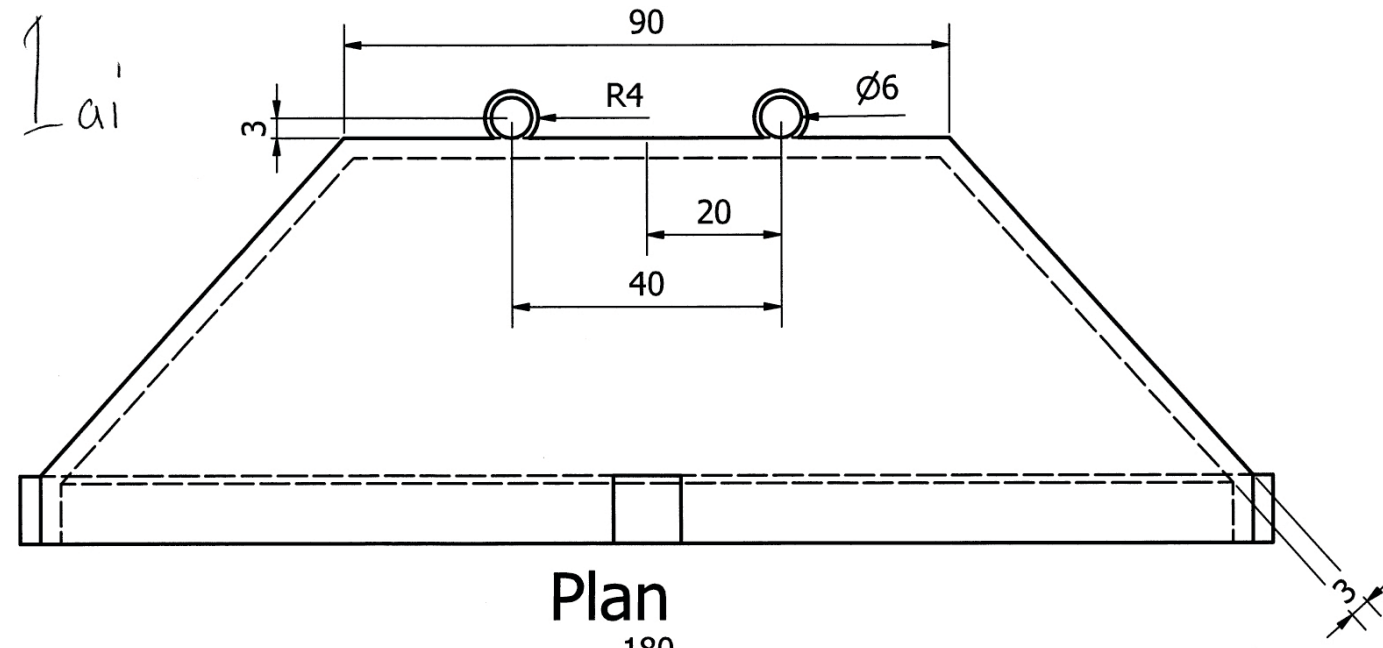

Plan

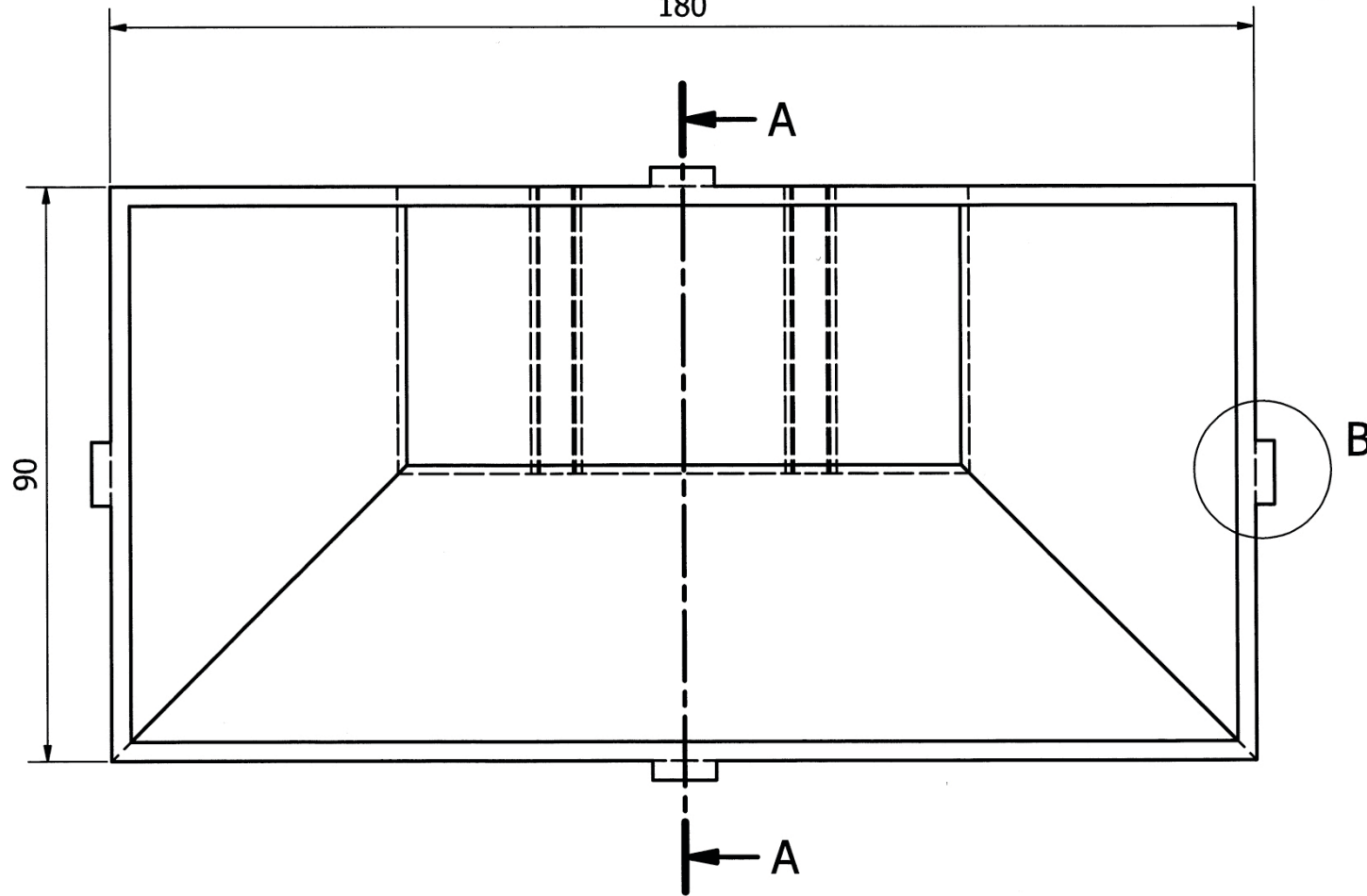

Elevation

Wall thickness = 3mm

B (2:1)

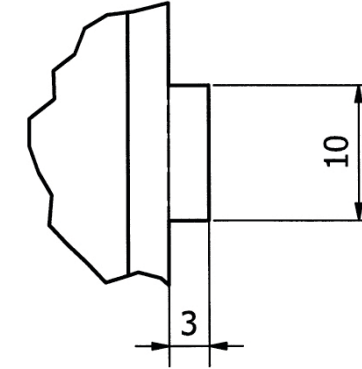

A-A (1:1)

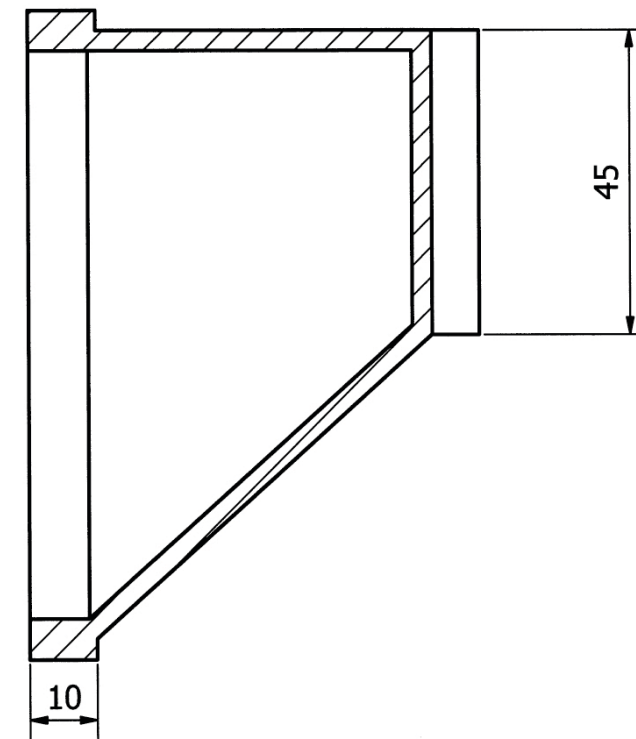

Name: [REDACTED]		Part Name: Tasklai - Back Casing	
Scale: 1:1	Date: 6/03/19		
SCN: [REDACTED]			

Task 1a ii

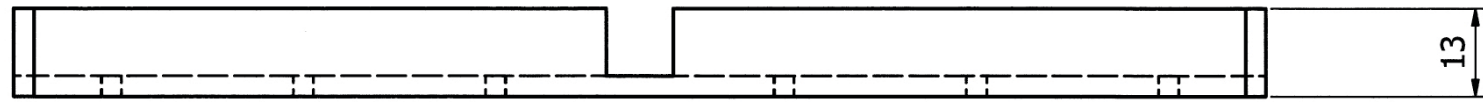

Plan

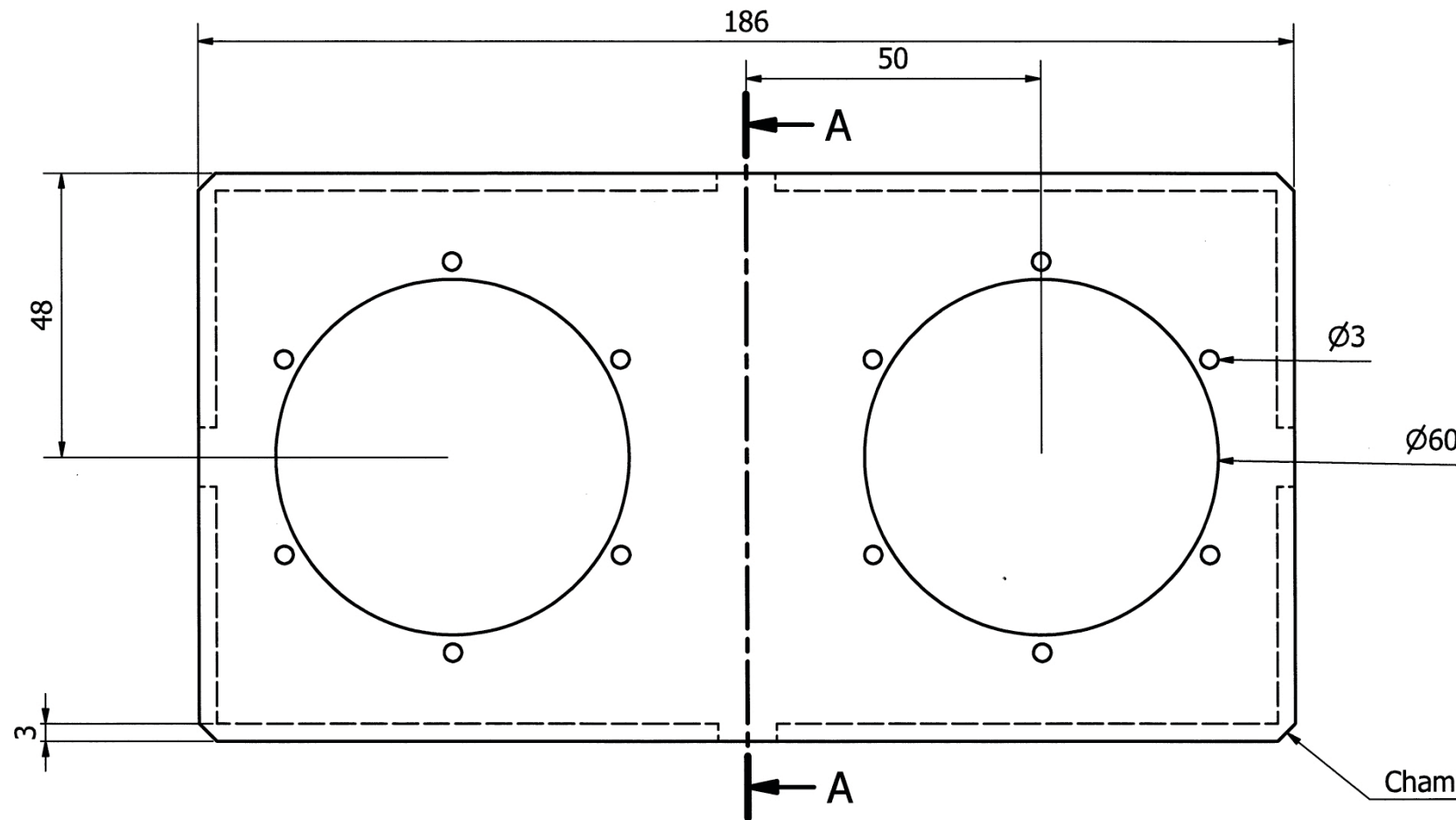

Elevation

A-A (1:1)

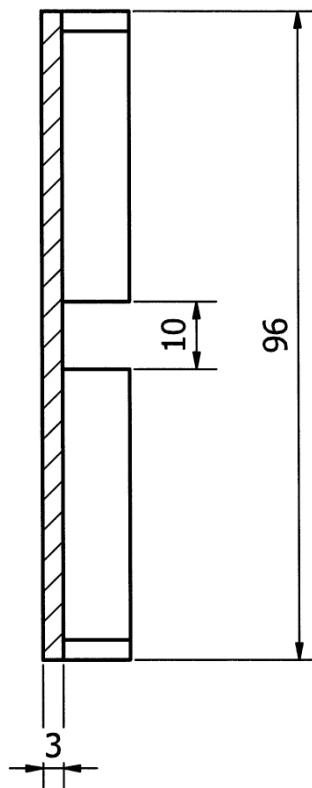

Sectional End Elevation

Wall thickness = 3mm

Name: [REDACTED]	Part Name: Task 1a ii - Front Casing
Scale: 1:1	Date: 6/03/19
SCN: [REDACTED]	

Task 1b

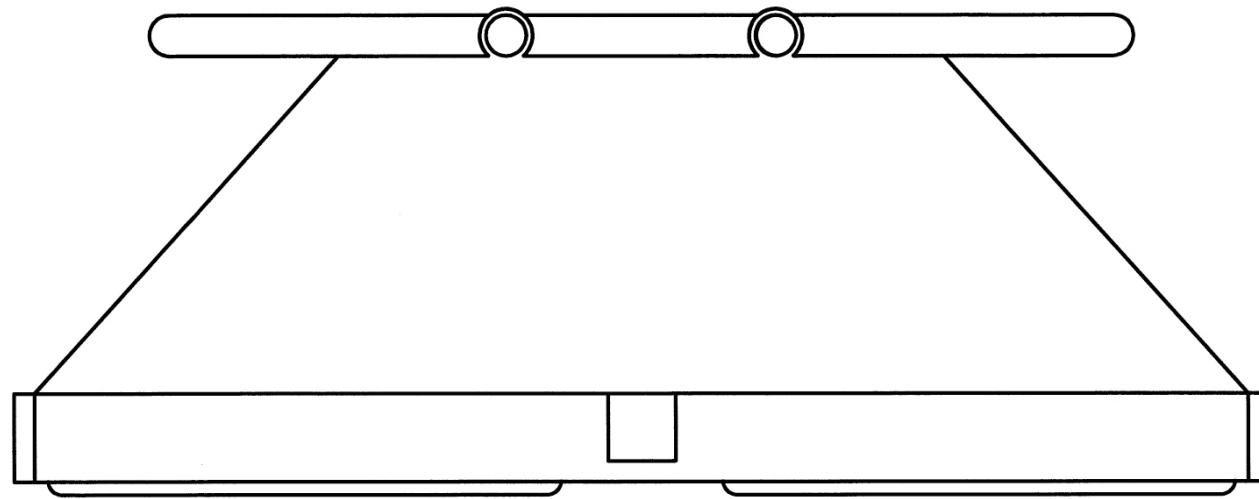

Plan

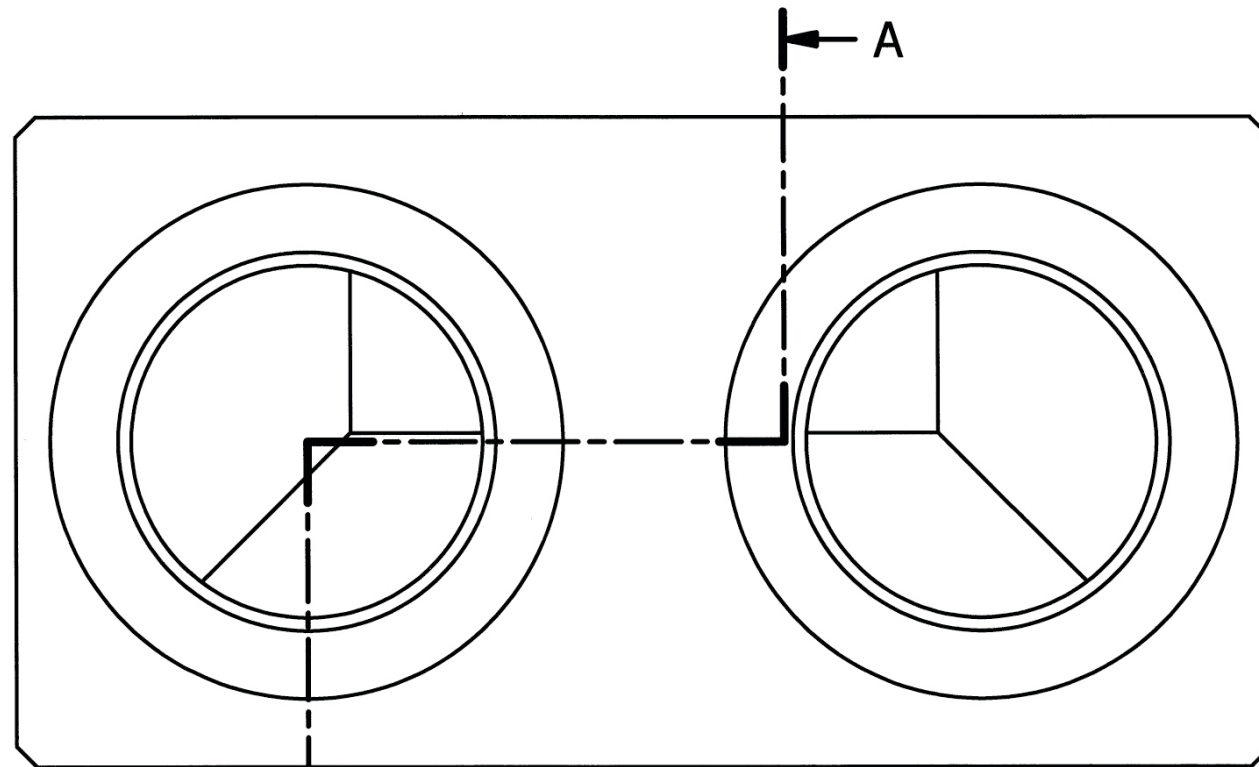

Elevation

B (2:1)

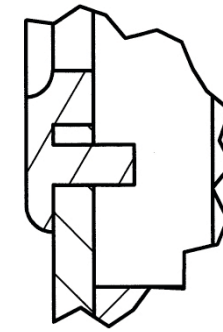

C (2:1)

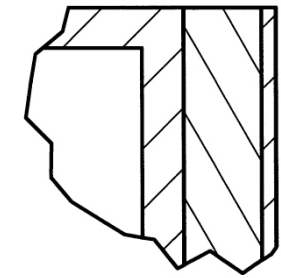

A-A (1:1)

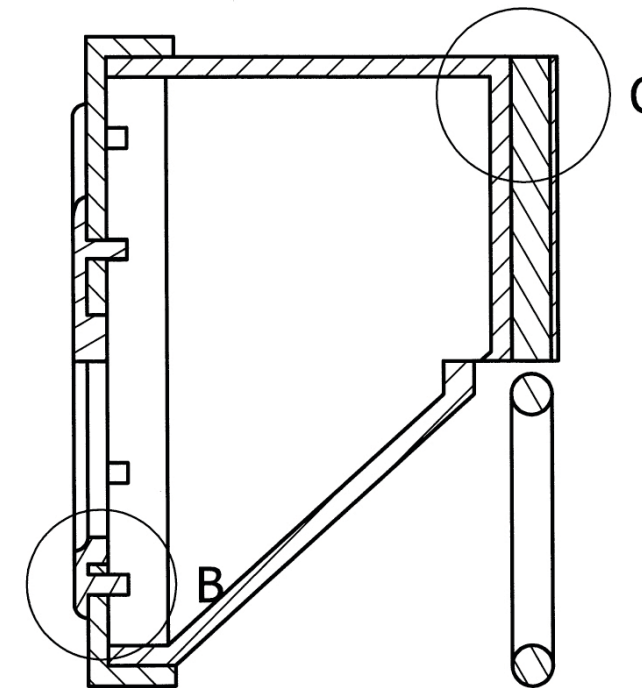

Stepped Sectional End Elevation

Name: [REDACTED]		Part Name: Task 1b - Assembled Spoke	
Scale: 1:1	Date: 7/03/19		
SCN: [REDACTED]			

Task 1c

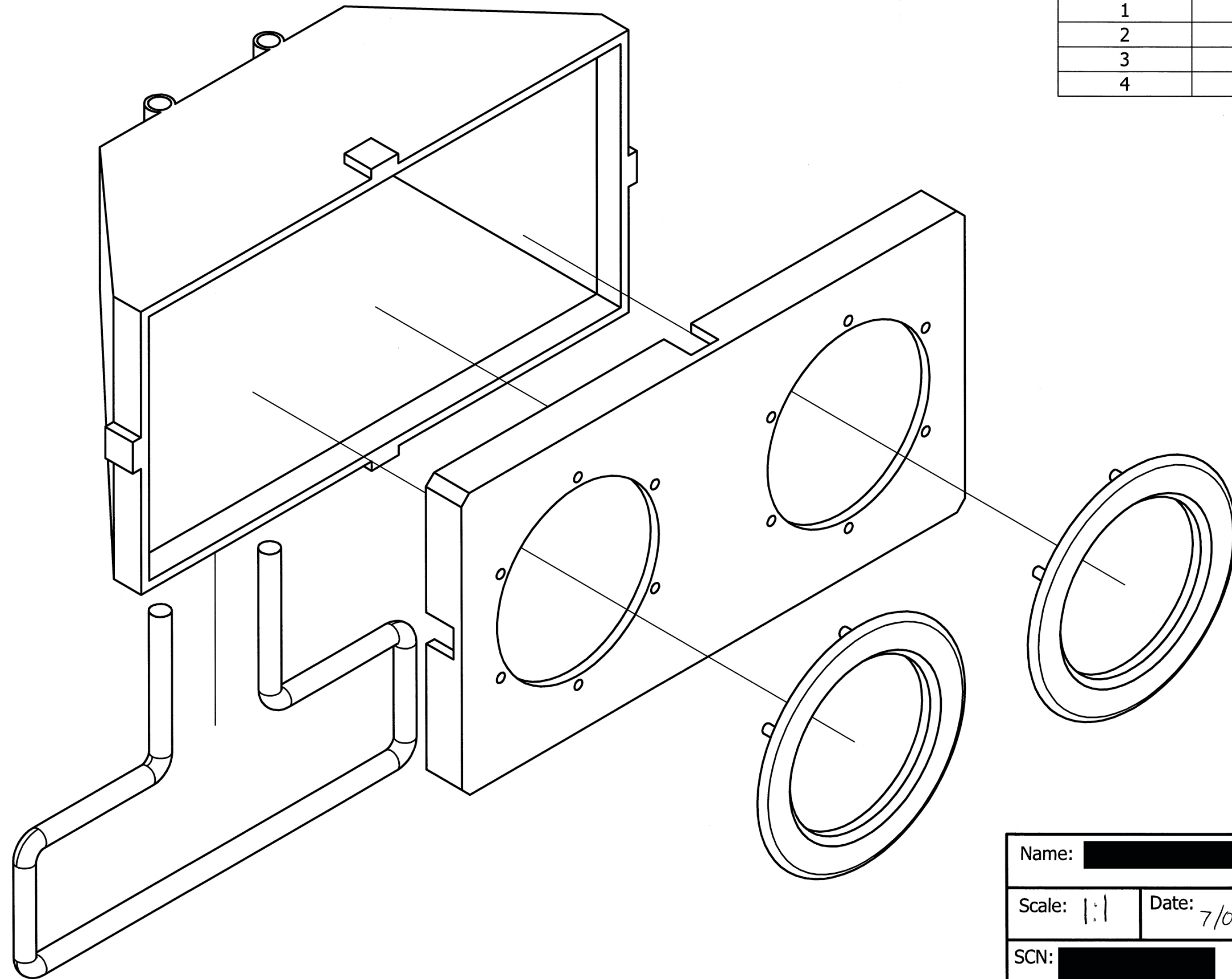

PARTS LIST		
ITEM	QTY	PART NUMBER
1	1	Back Casing
2	1	Front Casing
3	2	Speaker Disc
4	1	Stabalising Rod

Name: [REDACTED]	Part Name: Task 1c - Exploded Isometric	
Scale: 1:1	Date: 7/03/19	
SCN: [REDACTED]		

Task 2a



Task 2b

Preliminary Graphics

(not to scale thumbnails)

Thumbnail 1

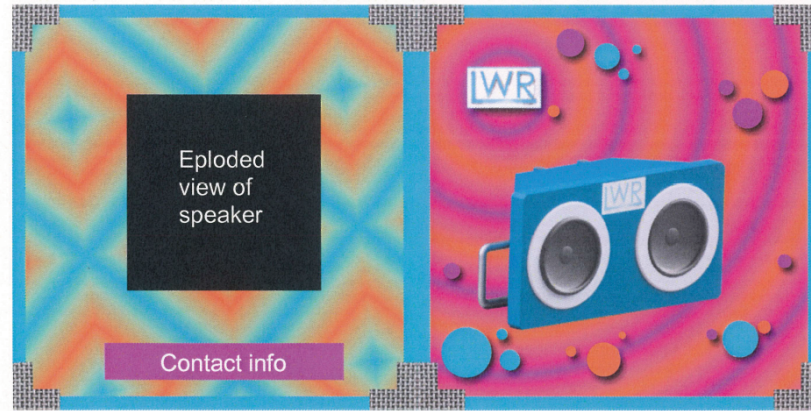

Back

Front

Thumbnail 2

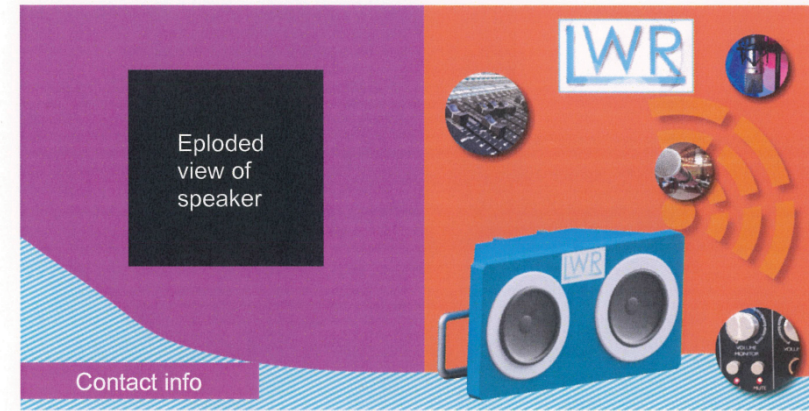

Back

Front

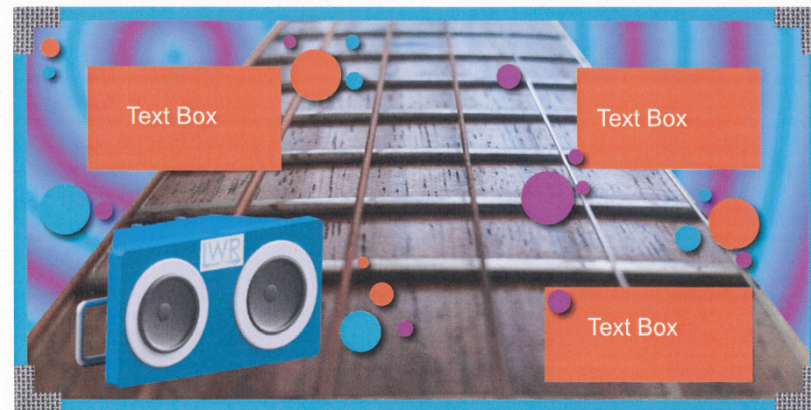

Double Panel Spread

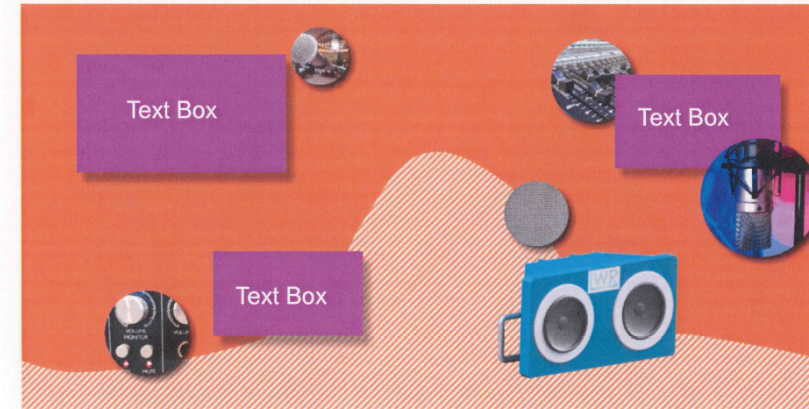

Double Panel Spread

Task 2c

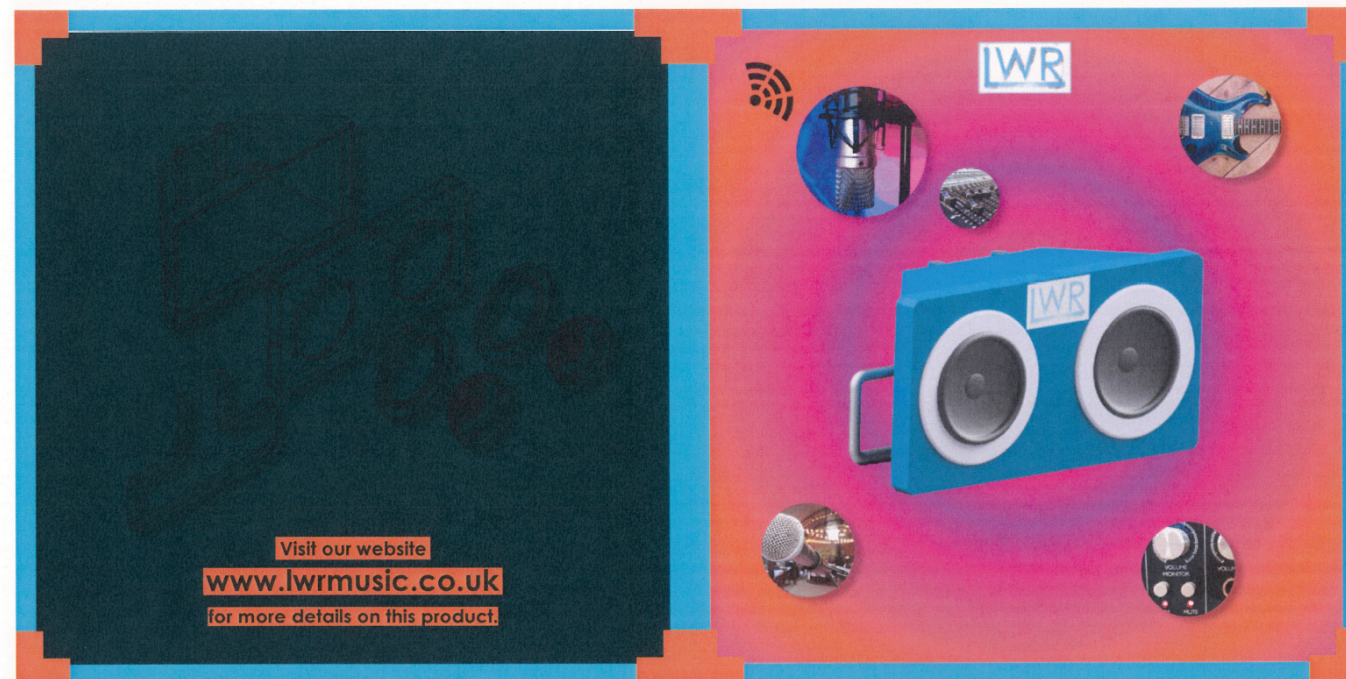

BACK

FRONT

Depth - This has been created through the use of layering, size and drop shadows throughout the piece. This is when the circles appear on front of and behind text boxes as well as when the circles are adjacent to another in larger/smaller sizes.

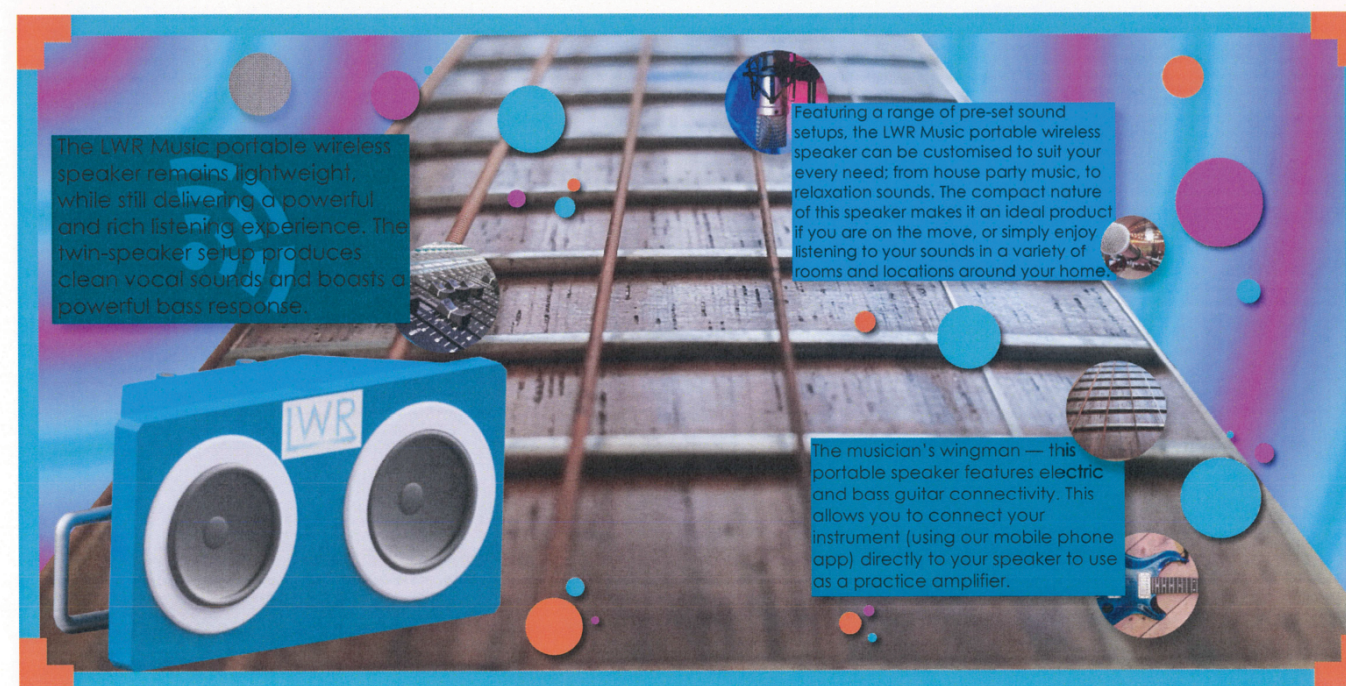

Double Panel Spread

Rhythm- This has been created through the repeat use of circles dotted about the page and the repeated circular lines on the background of the double panel spread.

Task 3a

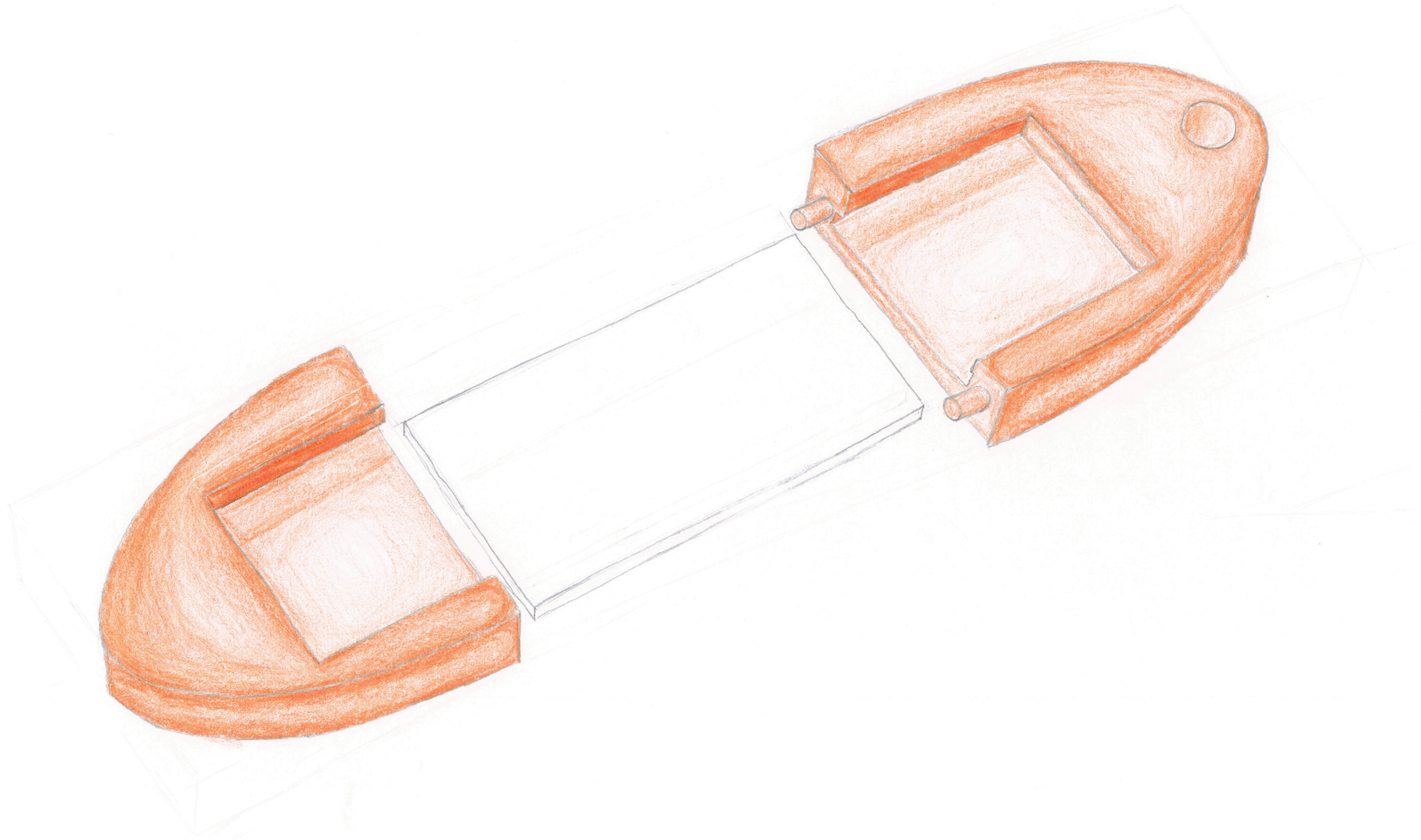

Task 3b

