

Candidate 4 evidence

Total marks — 90
Attempt ALL questions

MARKS
DO NOT
WRITE IN
THIS
MARGIN

1. Graphics of a new blender are shown below in Figures 1 and 2.

Figure 1

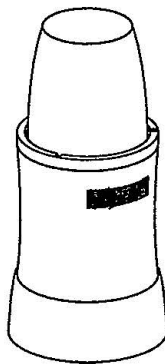

Figure 2



(a) Describe two illustration/3D rendering techniques applied to produce the realistic looking graphic shown in Figure 2.

2

- lighting and shadows
- fonts

(b) An alternative design is shown below for the plastic cup component. The CAD technician decides to produce this component in two stages.

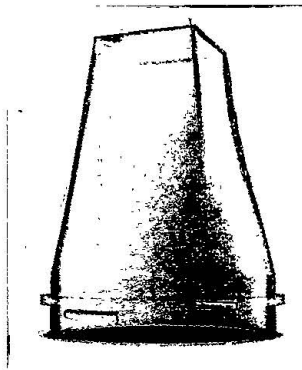

Alternative cup design

MARKS
DO NOT
WRITE IN
THIS
MARGIN

1. (b) (continued)

- (i) You must use the additional information provided on the supplementary sheet for use with question 1 (b) (i) to answer this question.

Describe, using 3D CAD modelling techniques, how the technician would complete Stage 1 as shown in the working drawings.

6

You may use sketches to support your answer.

① Select a new plane and sketch a circle with $\varnothing 113$

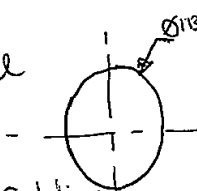

② extrude circle by 4mm, adding material on plane on

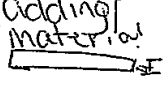

③ Select top of circle and sketch a circle with $\varnothing 105$ and extrude by 10mm adding material



④ Create new plane 110mm up and sketch a square (50 □)

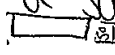

⑤ Use the loft tool to connect adding material

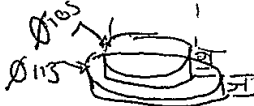

⑥ Use the shell tool to leave an 8mm side on the model, removing material

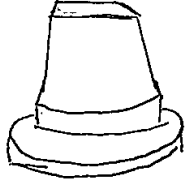

MARKS
DO NOT
WRITE IN
THIS
MARGIN

1. (b) (continued)

- (ii) You must use the additional information provided on the supplementary sheet for use with question 1 (b) (i) to answer this question.

The CAD technician adds additional features to allow the lid to lock into position, shown in red in Stage 2.

Describe how, using only the 'revolve' 3D modelling technique, the CAD technician created the additional features.

5

① Create a new plane

② ~~Sketch~~ Sketch the following

③ Extrude with semi-circle adding material

④ Use Revolve tool (360°) to create 2, equally spaced features, adding material

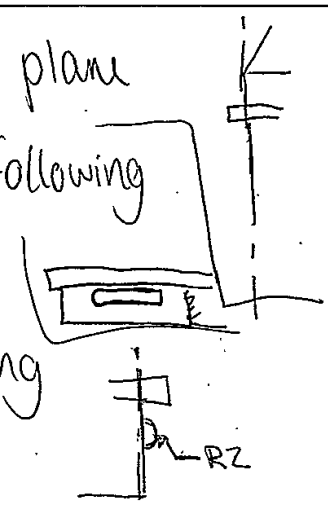

DO NOT
WRITE IN
THIS
MARGIN

1. (continued)

- (c) A concept design for the blade sub-assembly for the blender is produced. The two blades shown have been constrained to the pin using 3D CAD modelling software.

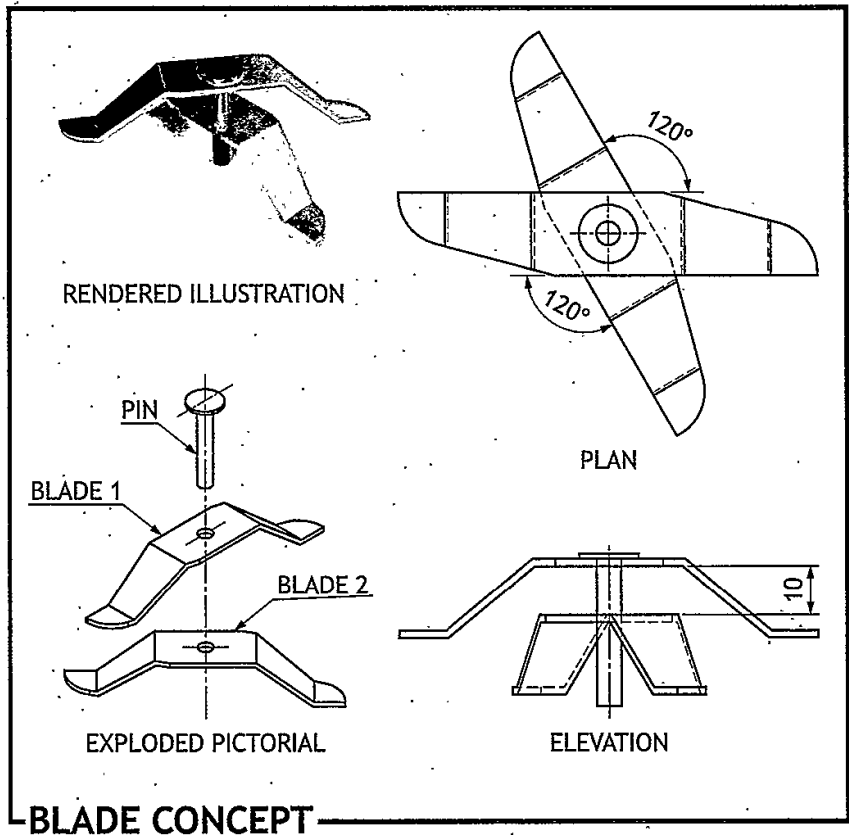

MARKS DO NOT WRITE IN THIS MARGIN

1. (c) (continued)

Describe the steps required to constrain the blades and pin to each other. You may annotate Figure 1 to help with your answer.

4

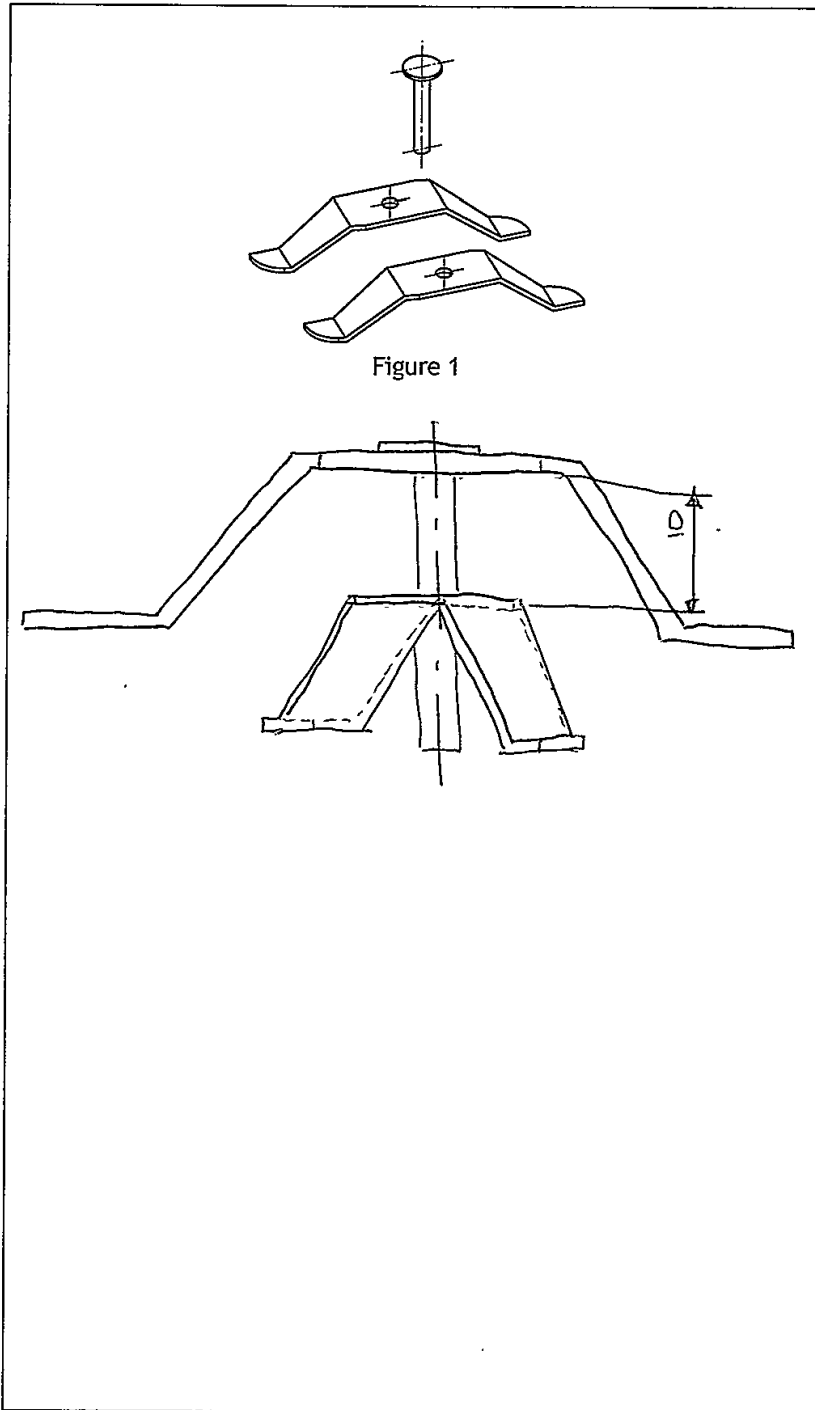

MARKS

DO NOT
WRITE IN
THIS
MARGIN

2. An incomplete enlarged sectional view of a wheel assembly is given below. Using the information provided on the supplementary sheet for use with question 2, complete the sectional view by adding appropriate hatching.

4

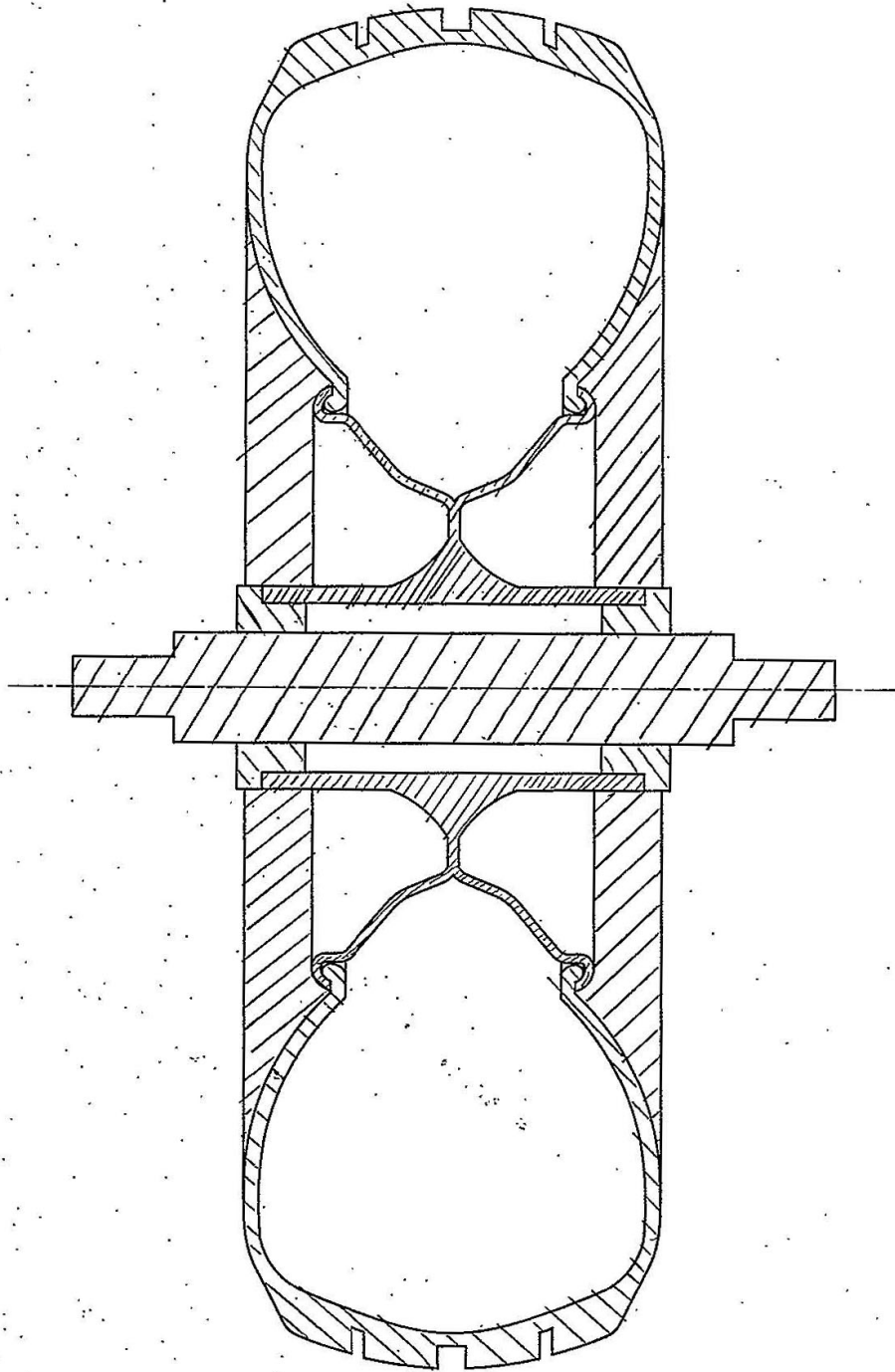

SECTION A-A

3. A graphic designer is producing content for Scotrock, a new Scottish music festival. The logo designs below are exported as vector files.

Version 1



Version 2



MARKS
DO NOT
WRITE IN
THIS
MARGIN

- (a) (i) Describe two advantages of exporting the logo shown in the vector format, as opposed to raster. 2

It can be any size and still maintain the same quality, as a vector (raster quality gets lower with bigger size)
As a vector, it is a smaller file size whereas the file size would be larger if it was a raster file

- (ii) State the name of a vector file extension which the logo could be exported as. 1

.STEP

- (iii) The graphic design company operate a paperless office. Describe two advantages for the company of operating a paperless office. Do not include environmental benefits from reduced paper. 2

Clients can receive their designs quicker as no need for postage or appointments
Can bring the cost of designs down as paper and ink are not needed which may incline potential customers to use your company.

[Turn over

3. (continued)

MARKS
DO NOT
WRITE IN
THIS
MARGIN

A draft graphic for the festival security passes is shown above.

- (b) (i) Describe two instances where the designer has used line to enhance the layout of the graphic. 2

- In the middle of the bigger boxes to separate information so it is easier to read and guides the eye ^{through} the text
- Around the white box at bottom to keep design united.

- (ii) Describe two instances where the designer has used alignment in the graphic. 2

- text in bigger box centred and aligned ^{end of} with subtitle
- boxes of colour aligned with title to create structure.

- (iii) Explain how the designer has used balance in the graphic. 2

- Used equal amount of colour and white space to balance out colour
- Used a bigger font for less information to balance with the more info on the other side of the design

3. (b) (continued)

MARKS

DO NOT
WRITE IN
THIS
MARGIN

(iv) Describe two instances where the designer has created contrast in the graphic.

2

- Used different serif and sans-serif fonts ^{in different sizes} to create contrast
- Used different colours for different kinds of people to create contrast

(c) The designer presents a proposal for a bus timetable design as shown below.



(i) State two advantages of using a sited environment when presenting desktop publishing work to clients.

2

- to show what the final product will look like in the environment it is made for
- shows product in different lightings

(ii) The festival organisers decide to use digital screens to display the bus timetable instead of printing them. Describe three advantages to the festival organisers of using digital screens over traditional printed timetables.

3

- costs less as no printing required.
- If it rains, the digital screens are waterproof whereas paper would get ruined.
- easier to change details as you don't have to start over. you just change details on a computer

3) (continued)

MARKS

DO NOT
WRITE IN
THIS
MARGIN

(d) You must use the graphic provided on the supplementary sheet for use with question 3 (d) to answer this question:

(i) Describe how the designer has used texture to enhance the impact of the graphic.

2

◦ Used metal texture behind title to make title stand out and be in the foreground

◦ used different colours to make the lettering stand out

(ii) Describe two ways the designer has used depth within the publication.

2

◦ used an image with text over top to send image to background

◦ used a drop shadow to ensure text is in the foreground

(iii) Describe two ways the designer has used emphasis within the publication.

2

◦ emphasised bus route as used black text on white background

◦ emphasised title as used a gradient background with the lightest part under title to show emphasis.

(iv) Describe two ways the designer has used unity within the publication.

2

◦ Used a select colour palette (black, blue, white, pink/purple) to create unity.

◦ used titles to unify information

MARKS	DO NOT WRITE IN THIS MARGIN

3. (d) (continued)

- (v) Explain two ways the designer has used grid structure within the publication.

2

- bus timetable in a grid table to show ^{organisation}
- packages in a table (grid) (white) to show uniformity and makes it easy for the customer to find the right package for them

The layout was produced using layers in desktop publishing software.

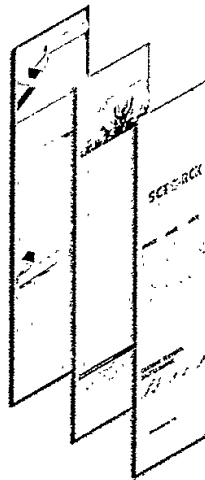

- (vi) Describe two advantages to the graphic designer of using layers to produce this layout.

2

- ensures each type of graphic stays in the correct place.
- ensures you can change one part of the design without moving it all

[Turn over

4. Parts for a retractable kickstand for a scooter are shown below.

DO NOT
WRITE IN
THIS
MARGIN

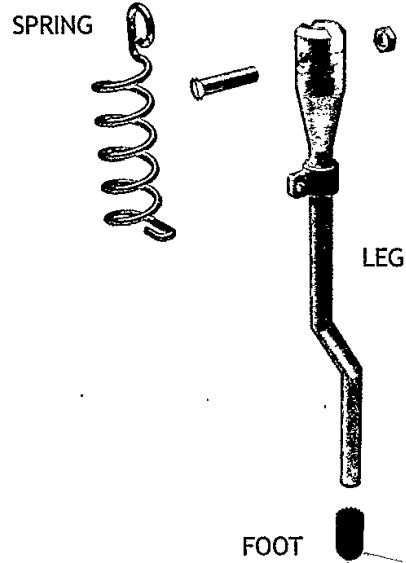
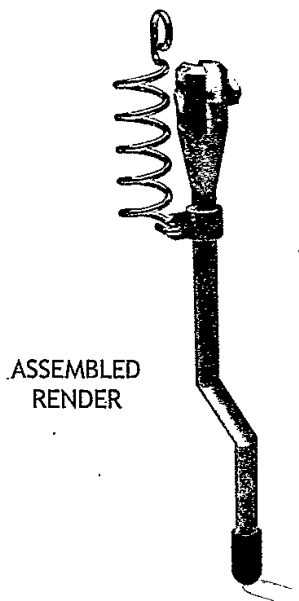
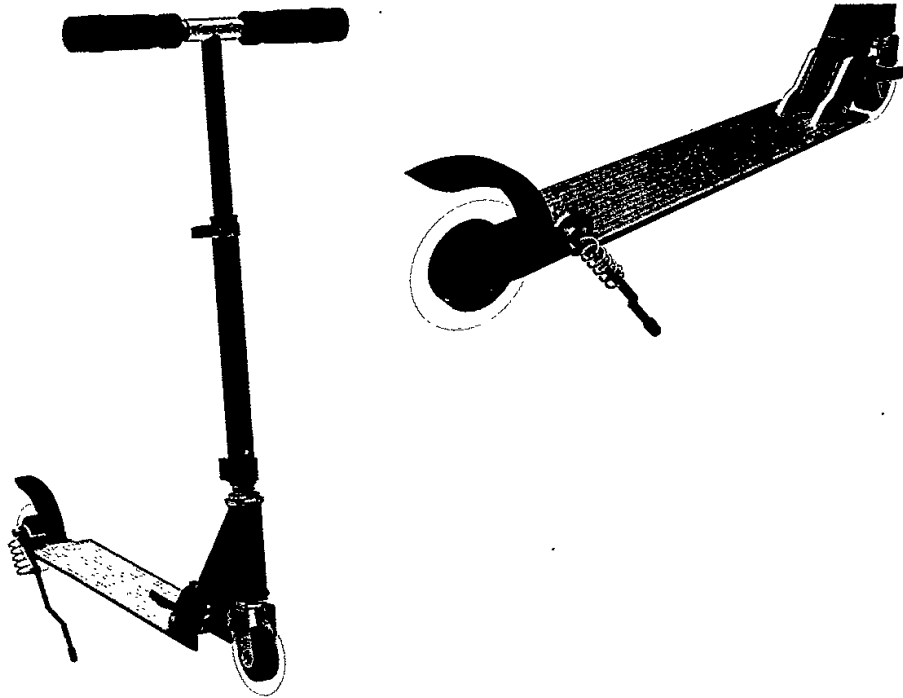

4. (continued)

MARKS
DO NOT
WRITE IN
THIS
MARGIN

- (a) The spring was modelled as a separate component using 3D CAD.
Describe the 3D CAD modelling technique used to model the spring.
You must make reference to the dimensions given.
You may use sketches to illustrate your answer.

3

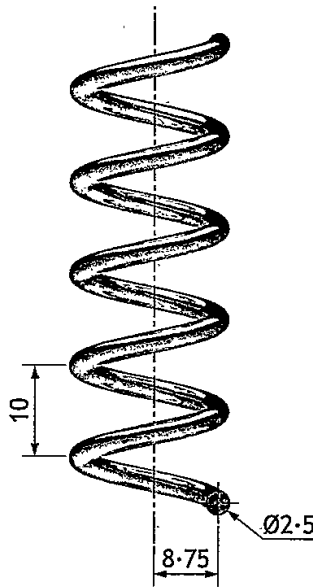

- ① Select a new plane and draw a circle with $R8.75\text{mm}$
 - ② Select a perpendicular plane and sketch circle with $\text{Ø}2.5\text{mm}$ using point on circumference of other circle as centre
 - ③ Use helix tool to create however many rotations you want with a spacing of 10mm in between each, adding material
-

4. (continued)

- (b) The leg was 3D CAD modelled as a single component.
 Describe the modelling techniques used to generate the component.
 You may use sketches to illustrate your answer.

MARKS
 DO NOT WRITE IN THIS MARGIN

6

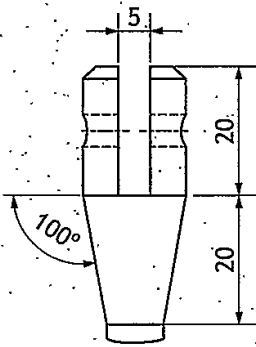

DETAIL VIEW B
 (1:1)

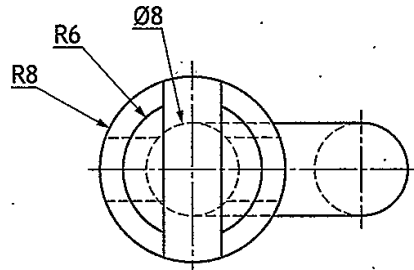

DETAIL VIEW A
 (2:1)

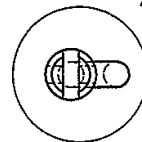

PLAN

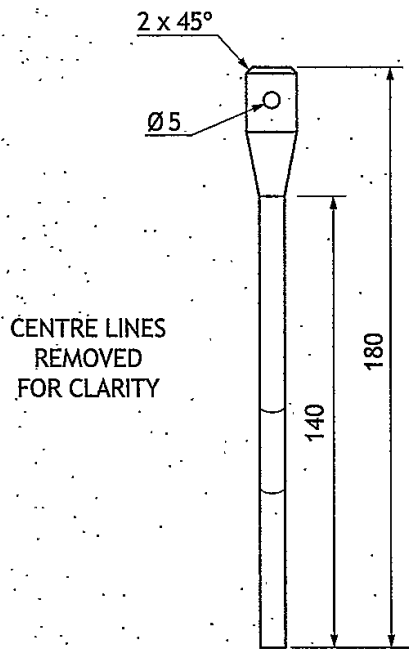

CENTRE LINES
 REMOVED
 FOR CLARITY

END ELEVATION

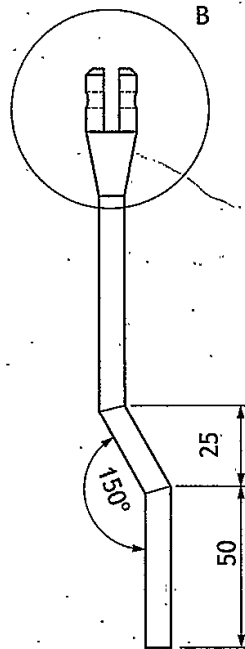

ELEVATION

SCALE 1:2

4. (b) (continued)

MARKS
DO NOT
WRITE IN
THIS
MARGIN

① Select new plane and draw the following

② Use the revolve tool (360°) adding material



③ Draw the following =

④ Select perpendicular plane and sketch two circles with R8 & R6 (using point on line as centre)

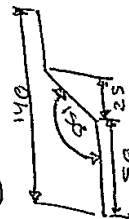

⑤ Select area between circles and use sweep tool, adding material

⑥ join two parts together to create a single component

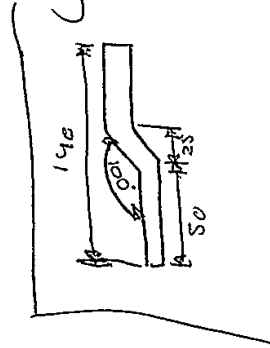

⑦ Select find centre and sketch circle ϕ s

⑧ select circle and remove material all the way through

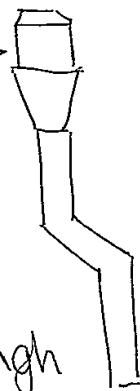

4. (continued)

MARKS	DO NOT WRITE IN THIS MARGIN
	3

- (c) The foot was 3D CAD modelled using the revolve command.

Describe the modelling edit used to complete the component from Stage 1 to Stage 2.

You may use sketches to illustrate your answer.

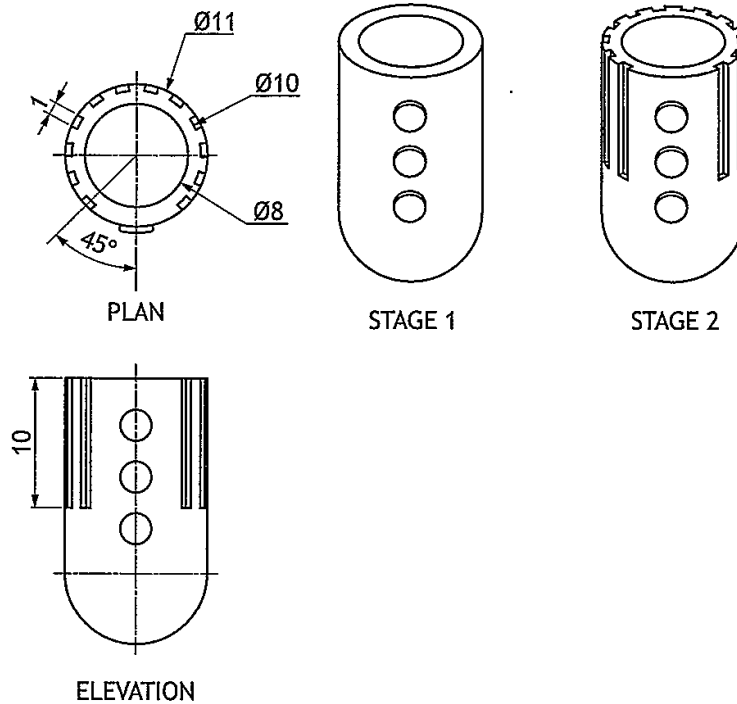

- ① Select plane on top of component
 - ② Sketch new circle with $\varnothing 10$
 - ③ Create rectangle with length 1mm
 - ④ Subtract material 10mm, removing material
 - ⑤ Use revolve tool (270°) to create 12 grips (equally spaced)
-

MARKS DO NOT WRITE IN THIS MARGIN

4. (continued)

The kickstand is connected to the scooter by an M5 countersink head screw. The length of the thread is 14mm.

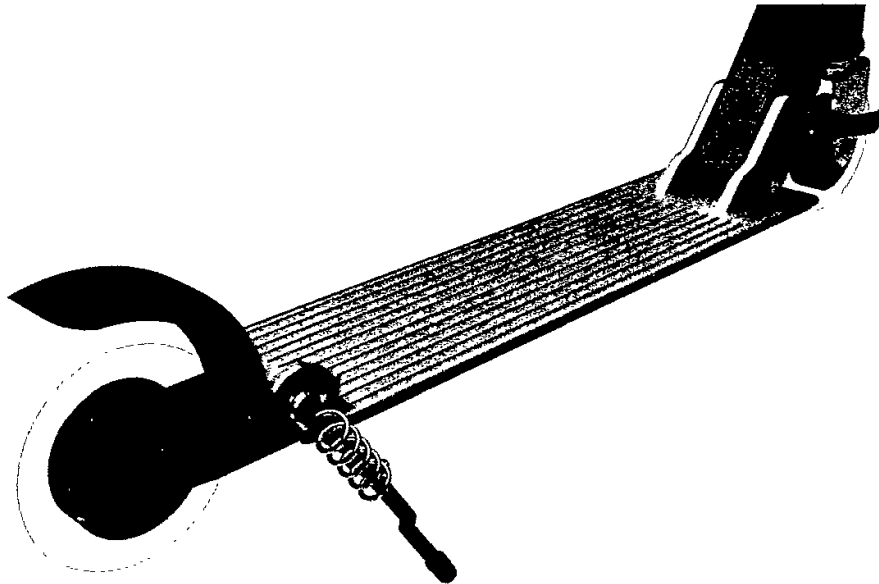

(d) Apply to the views below the correct British Standard conventions for

(i) the diameter of the bolt

1

(ii) the length of the thread

1

(iii) the convention for a thread.

2

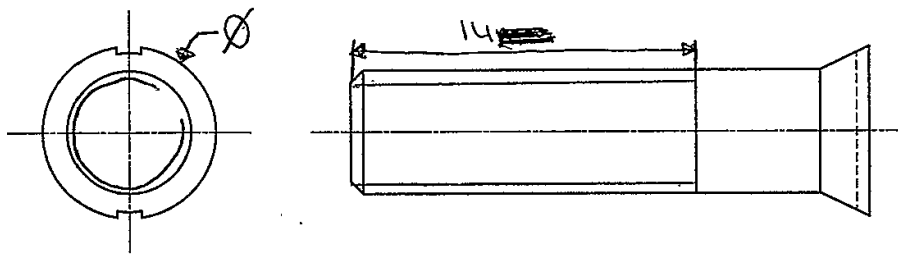

MARKS DO NOT WRITE IN THIS MARGIN

4. (continued)

(e) The assembly technician downloads an orthographic drawing from the company network. The technician immediately notices some issues with the drawing.

Identify from the drawing, five errors which are not correct to British Standard conventions.

5

- Spring overlaps with leg
- Dimensions should be mm
- Scale should be 2:1
- sizes do not have tolerances
- should not have break line

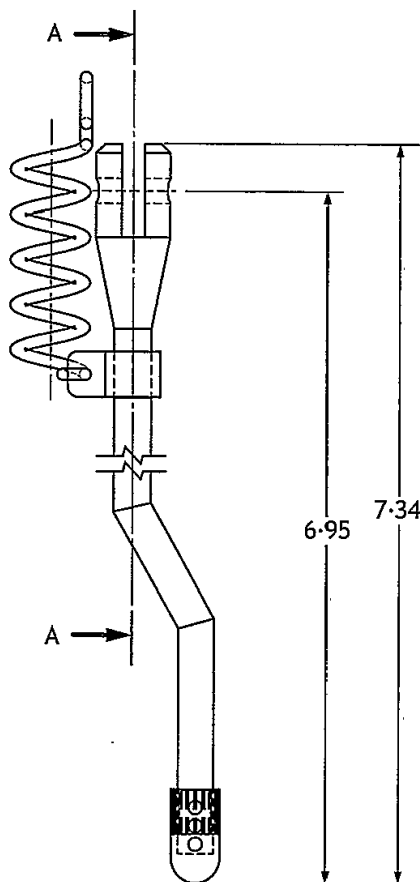

ELEVATION

DESIGNED BY M. AUTHOR	SCALE 1:2	DATE MAY 2019
KICKSTAND ORTHOGRAPHIC		
ALL DIMENSIONS ARE IN INCHES		

5. A design company has produced a range of graphics for a music festival.
During the planning process three of the graphics were submitted.

DO NOT
WRITE IN
THIS
MARGIN

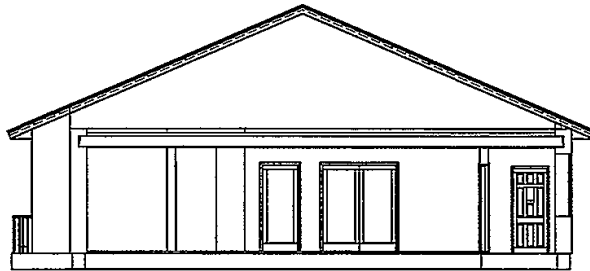

Figure 1

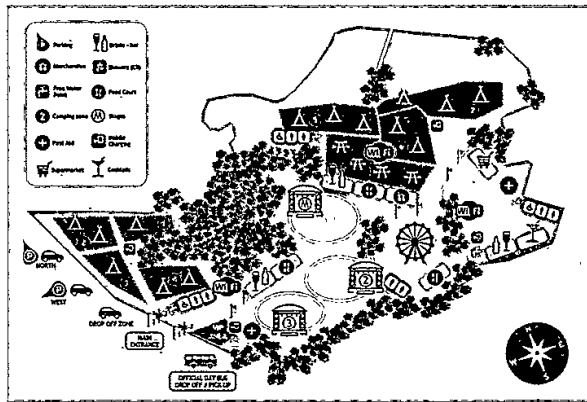

Figure 2

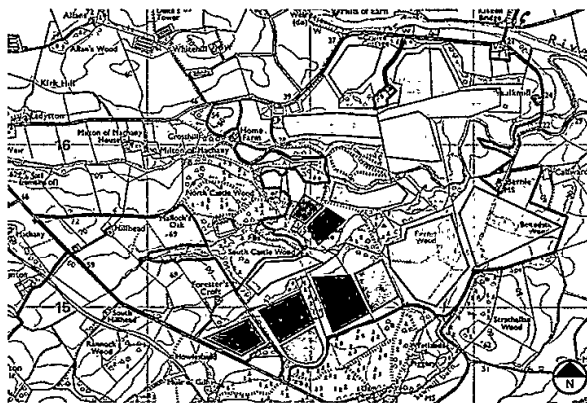

Figure 3

5. (continued)

- (a) Explain, with reference to preliminary, production and promotional graphics, the purpose of Figures 1, 2 and 3.

3

Figure 1

production graphic, shows manufacturer
how building should look

Figure 2

Promotional graphic, shows customer
what everything will be like, where
everything is

Figure 3

preliminary graphic, shows potential
of where things may go / how things
may look

- (b) State three features which should be shown on a British Standards location plan.

3

- direction
- scale
- angle (3rd angle, 1st angle) projection

MARKS
DO NOT
WRITE IN
THIS
MARGIN

5. (continued)

MARKS DO NOT WRITE IN THIS MARGIN

(c) Changes, shown in the Proposed Plan and Final Plan, were made during the planning stage. With reference to the graphics below, identify two reasons the camping areas marked with an X have been relocated.

2

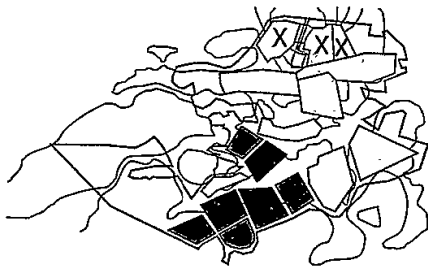

PROPOSED PLAN

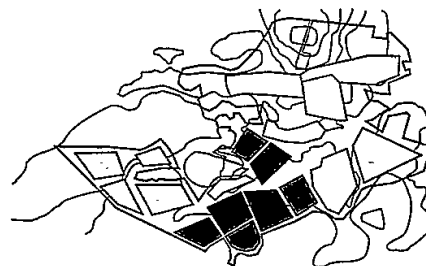

FINAL PLAN

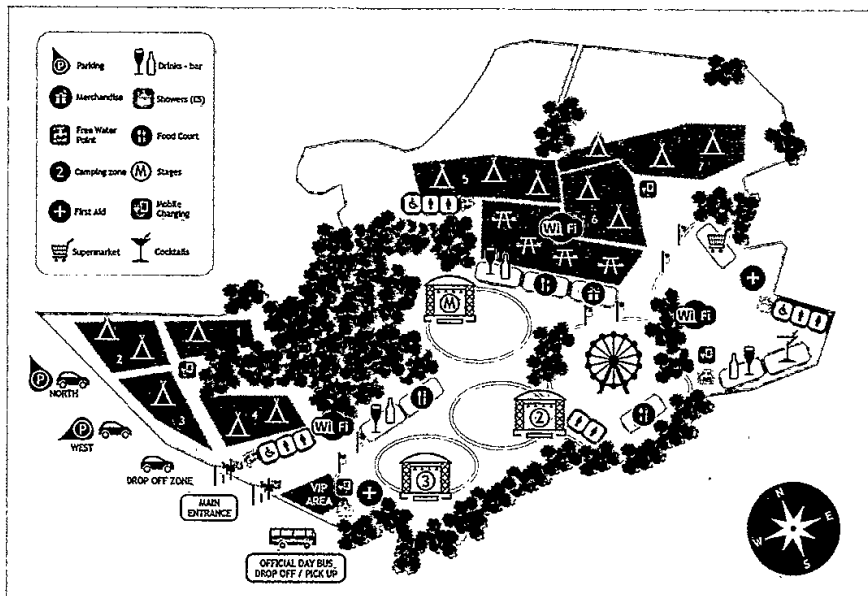

- not close enough to utilities before
- too steep a hill on the proposed plan for camping

5. (continued)

The site plan for the VIP area is shown below.

NOTE
2 CABIN STYLE TEMPORARY BUILDINGS
DECKING CONNECTS BOTH CABINS
RECLAIMED TIMBER USED FOR DECKING

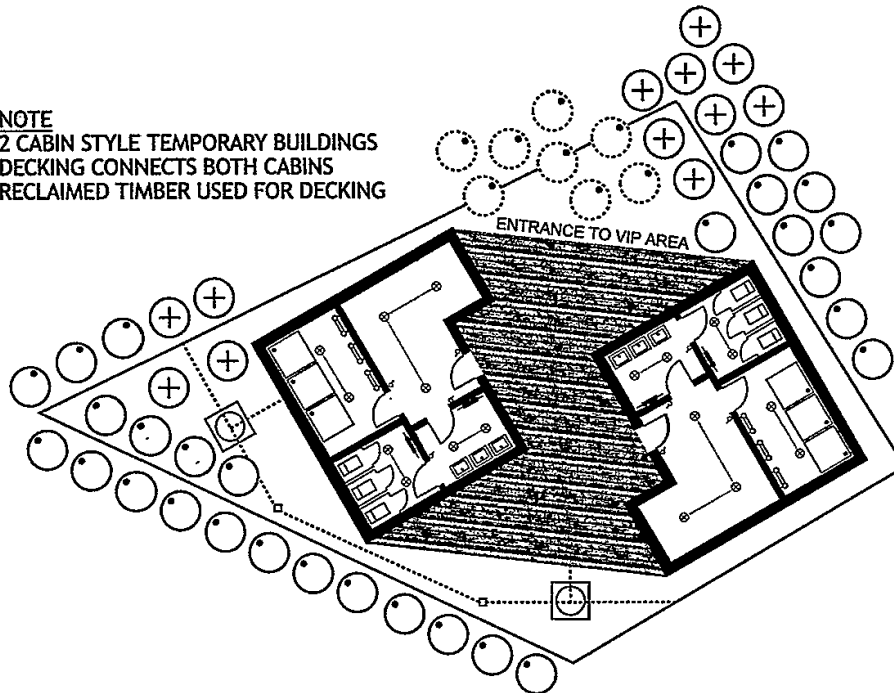

Architects had to plan around the existing environment, to create two temporary buildings and an outdoor wooden decking area.

- (d) State how many existing trees are within the VIP boundary.

1

10

- (e) The site plan shows some existing trees had to be removed.
State a reason why this was necessary.

1

To create a clear entryway
to VIP area.

- (f) Describe how the architect has considered the environmental aspect of the site.

2

° plans to plant more trees than
the ones they are cutting down
° Using recycled wood for decking
so no extra trees need to be
removed

MARKS DO NOT
WRITE IN
THIS
MARGIN

5. (continued)

MARKS	DO NOT WRITE IN THIS MARGIN
2	

- (g) State two factors that influence the choice of scale in a floorplan.

2

- size of floorplan
- size of paper / device you want to display your floorplan on

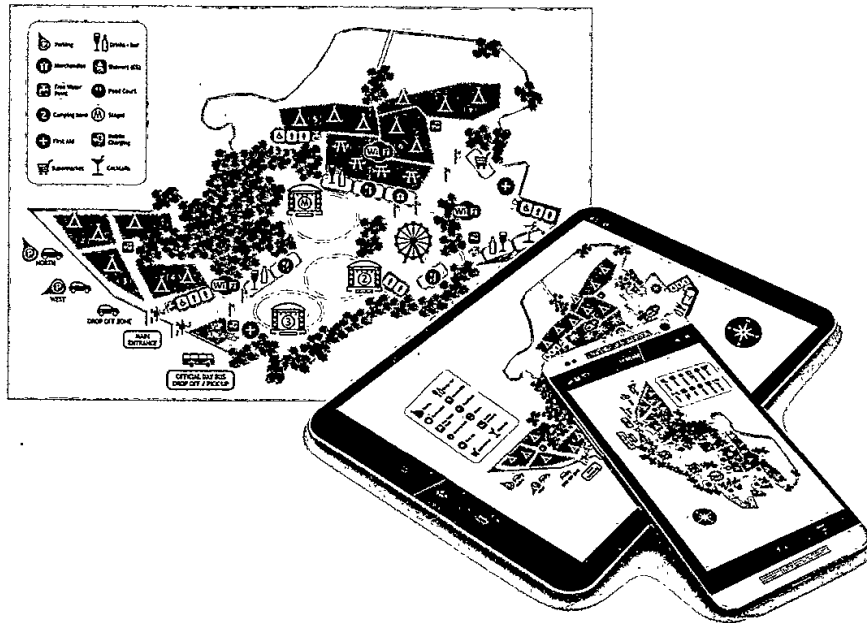

- (h) The company plans to have both a hardcopy and electronic version of the festival site plan as shown above.

State two things that the designer would have to consider when making the site plan suitable for a range of electronic devices.

2

- what type of file to use
- different languages to ensure everyone can understand what is happening no matter what language they speak.

5. (continued)

- (i) The company has set up a website and social media link for the event, allowing festival goers to connect with fellow attendees and those not in attendance.

Describe why the companies promoting and advertising the event may like this live link.

- ensures queries are answered quickly
- people are able to find information very easily

MARKS
DO NOT
WRITE IN
THIS
MARGIN

2

[END OF QUESTION PAPER]