

Candidate evidence

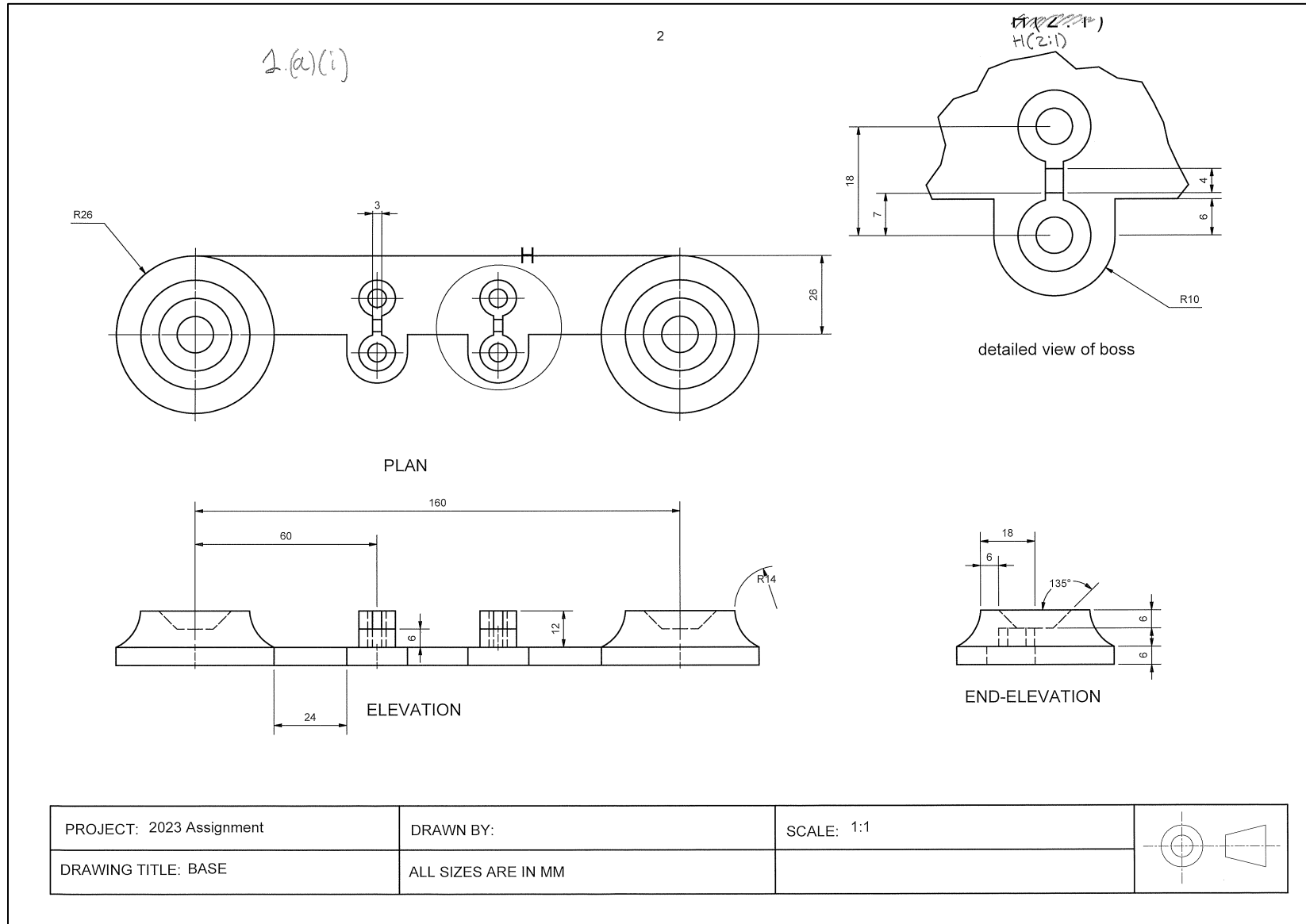

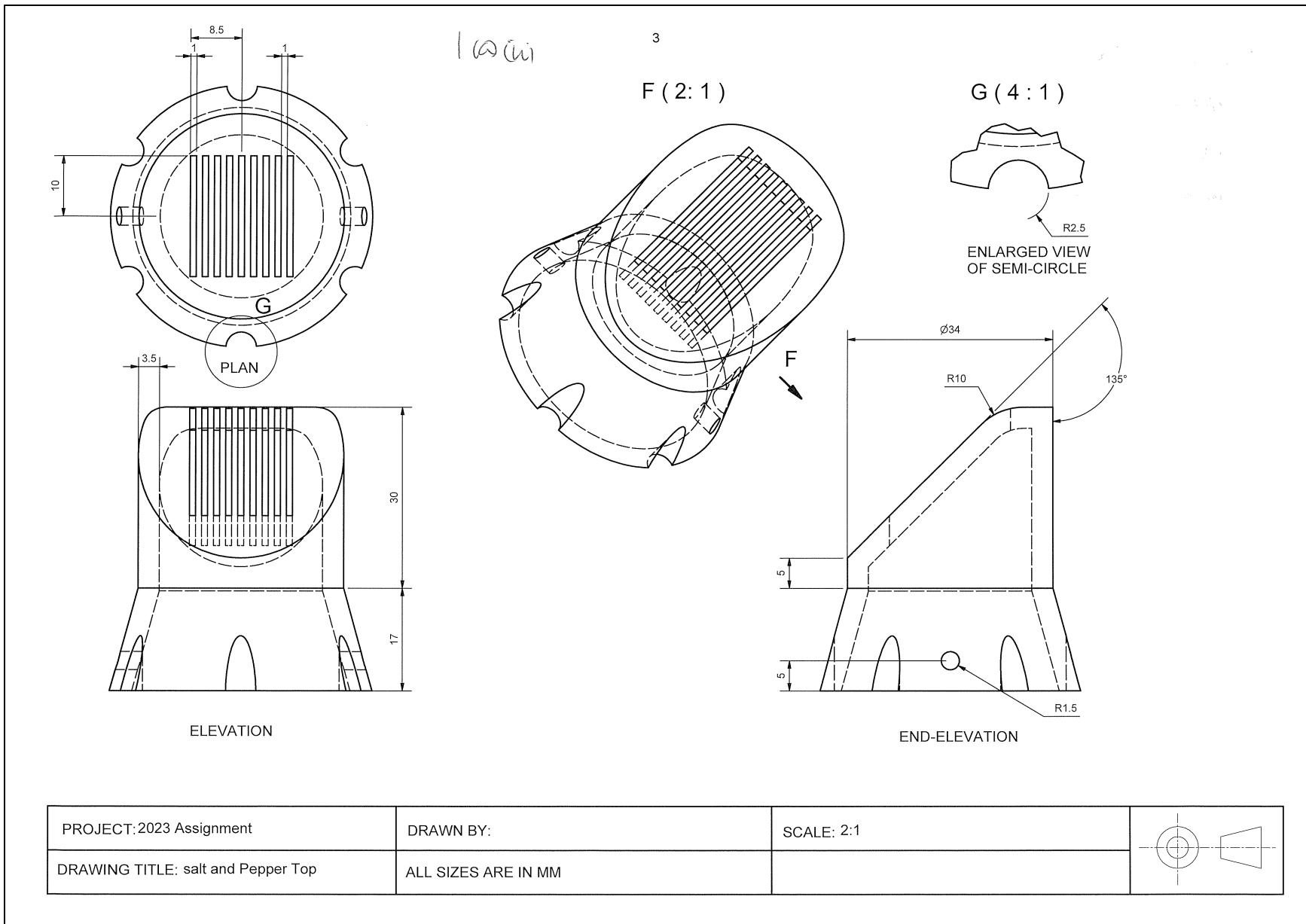

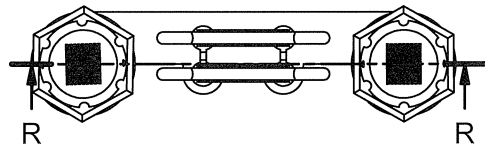

Plan

U (2:1)
4

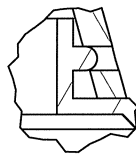

1/b

Details view of how salt and pepper top and bottom fit together

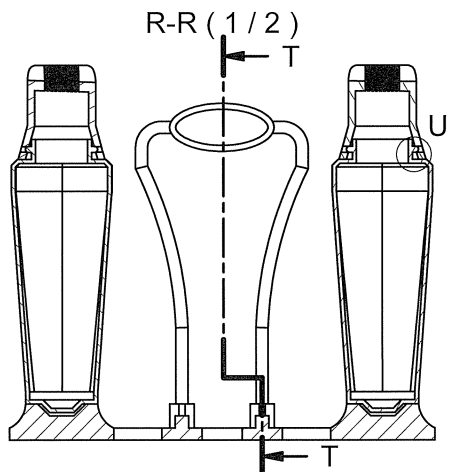

Sectional Elevation

T-T (1/2)



Stepped-Sectional End-Elevation

PROJECT: 2023 Assignment	DRAWN BY:	SCALE: 1/2	
DRAWING TITLE: Assembly	ALL SIZES ARE IN MM		

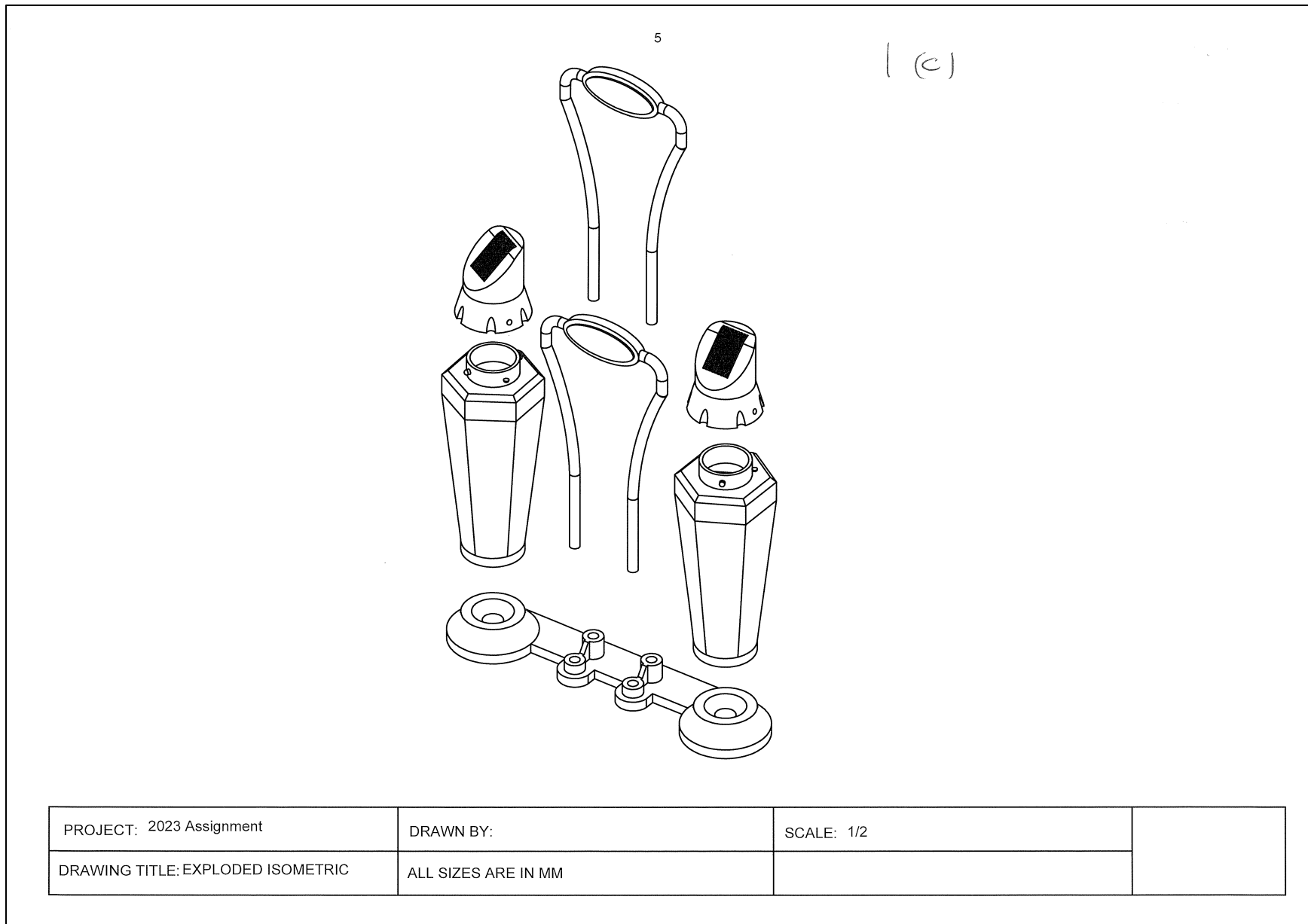

6

CYMK colour 3 (handwritten in red)

2 (a) (handwritten in red)

Rhythm used by repeating images across page to create unity allowing for the graphic as a whole to look complete.

Text centre aligned to make it more dominant in the page to bring attention towards it while also making the text look neat

Images cropped to better suit the environment of the graphic to create depth

All text being aligned to the left to make the text layout easier to read

Two very contrasting fonts with one being serif and the other being sans serif, while also one being bold and the other not. The sans serif font being bold as a sub title while the body text being the sans serif having less dominance.

White space at bottom of page to de clutter the already busy graphic to bring more attention to the text

CYMK colour 1

Sandwiches:
(gluten-free bread available)

- Parma ham and mozzarella
- Chargrilled chicken
- Brie and bacon
- Coronation chickpea (VG)
- Roasted vegetables with vegan pesto (VG)

Toasties:
(gluten-free bread available)

- Tuna melt
- Cheese and onion (V)
- Mozzarella, tomato and pesto (V)

Soups:

- Minestrone (V)
- Tomato and basil (VG)
- Scotch broth

Breakfast:

- Bacon and fried egg breakfast roll
- Home-made granola with berries and Greek-style yogurt (VG)
- Croissant with jam and butter (V)
- Fluffy pancakes with maple syrup (VG)
- Smoked salmon bagel

Sweet bakery:

- Empire biscuit (VG)
- Strawberry tart (V)
- Fruit scone (V)
- Chocolate brownie (V)
- Millionaire's shortbread (V, gluten-free)
- Lemon and lime cake (VG)
- Red velvet cupcake (V)

vegetarian (V), vegan (VG)

vegetarian (V), vegan (VG)

1 [Green swatch]

2 [Light green swatch]

3 [Blue swatch]

4 [Yellow-green swatch]

2 (09)

7

Text aligned down the left makes text layout easier to read, text is also columnned to make the graphic look neater.

Coffee:

- Deianas's ristretto
- Espresso
- Americano
- Latte
- Cappuccino

Tea:

- Breakfast tea
- Lemon and ginger
- Peppermint
- Camomile
- Red berry

CYMK colour 2

Pull quote at centre of page pulling the attention towards it

"An outstanding treat that won't be forgotten in a hurry!"

About Us:

Deiana's Café is a family-run business based in Aviemore. Mario Deiana moved to Scotland in 1957 and opened a small bakery on Grampian Road in Aviemore. Since opening, the business has expanded and now Deiana's Cafés can be found in locations all across Scotland. The chain of cafés was recently described by local restaurant critic Jeremy Dempsey as, "An outstanding treat that won't be forgotten in a hurry!". Mario retired in 2003 but can still be seen occasionally indulging in his signature Deiana's ristretto coffee in the original Grampian Road café.

Dairy-free alternatives available.

Brickwork background used to mimic the feeling of a cafe wall to create a sense of environment

Company Logo

White space pulls attention towards company logo and creates harmony in the page

B1

B2

Z(b)

8

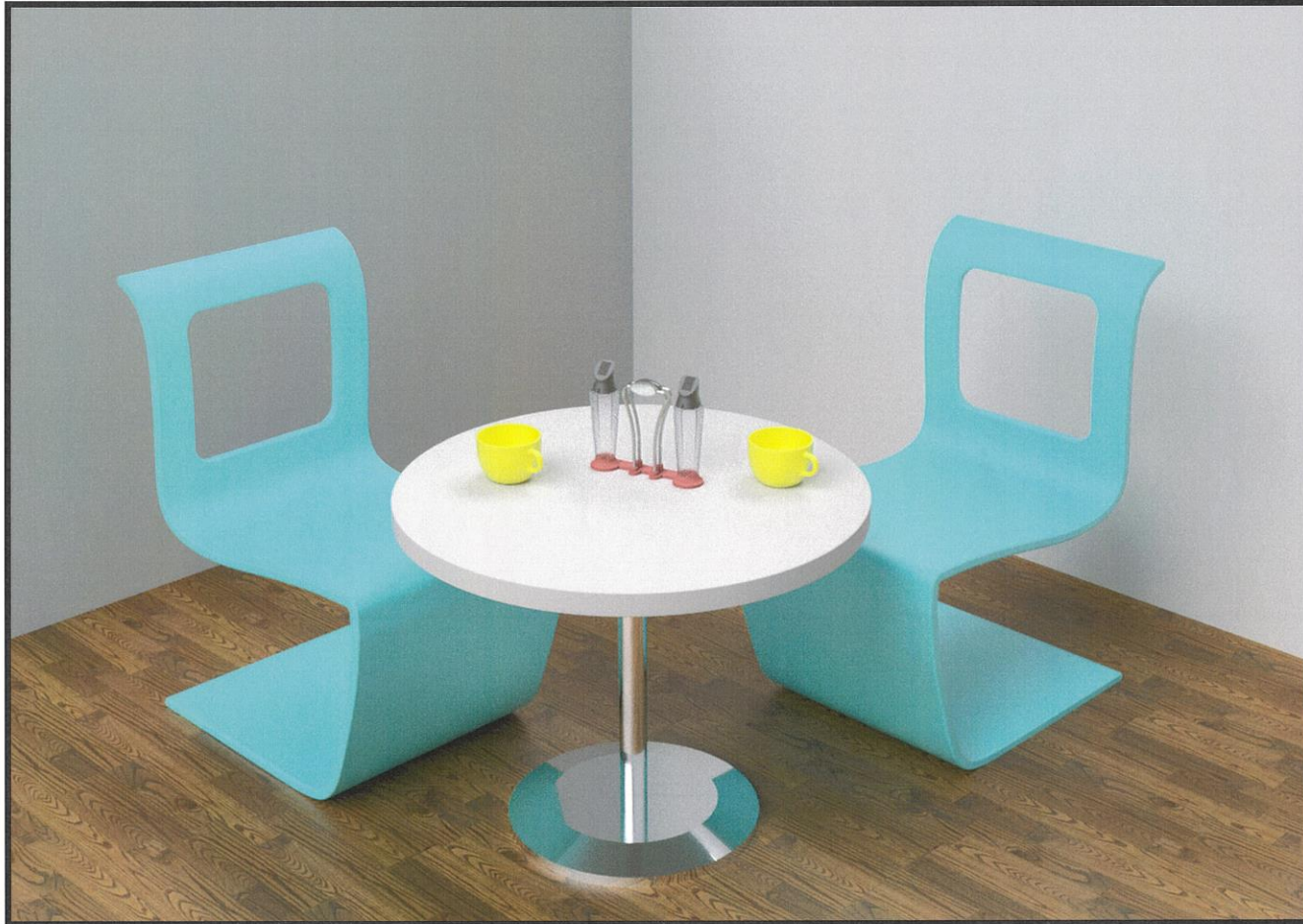

2(b)

9

