

PLAN

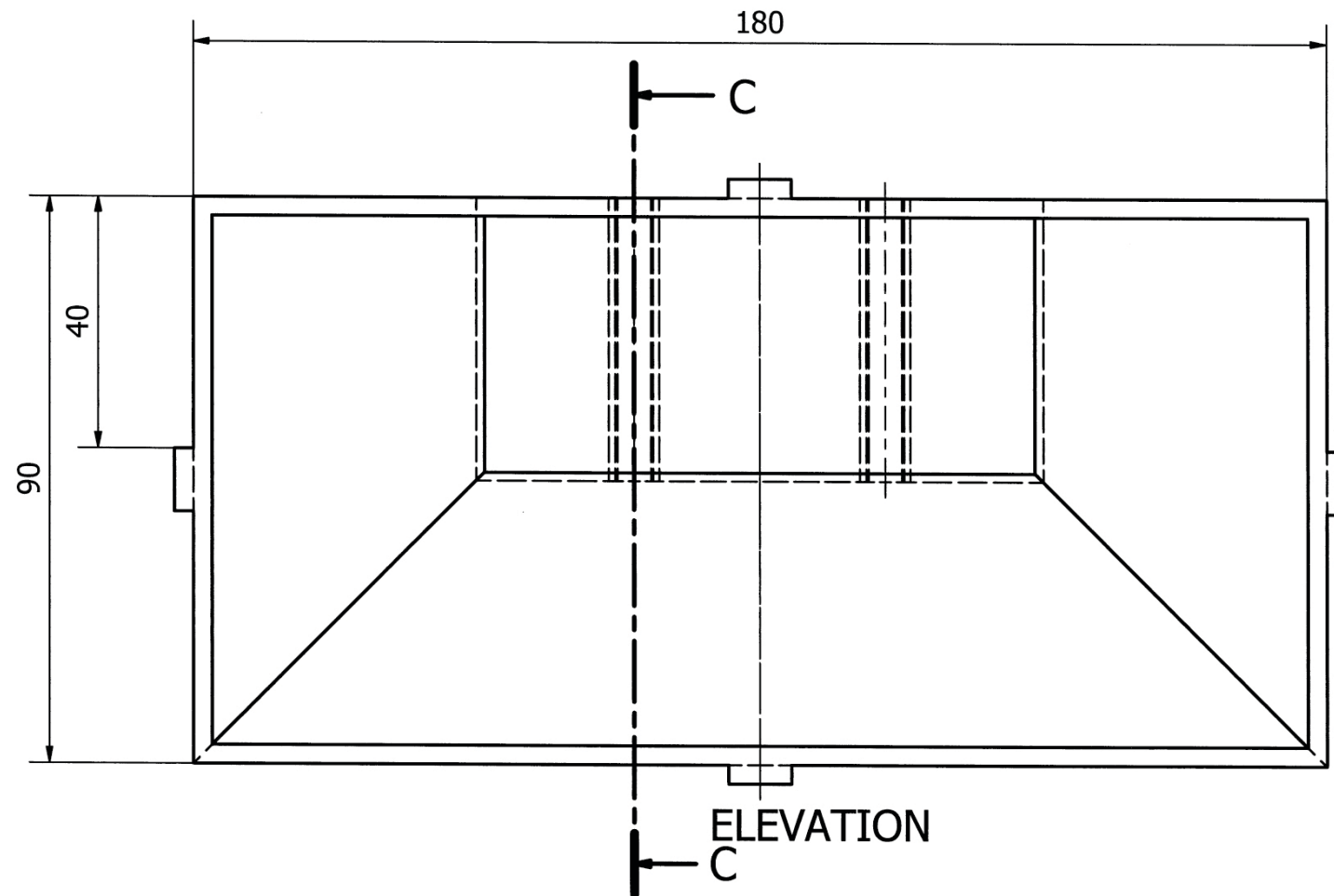

ELEVATION

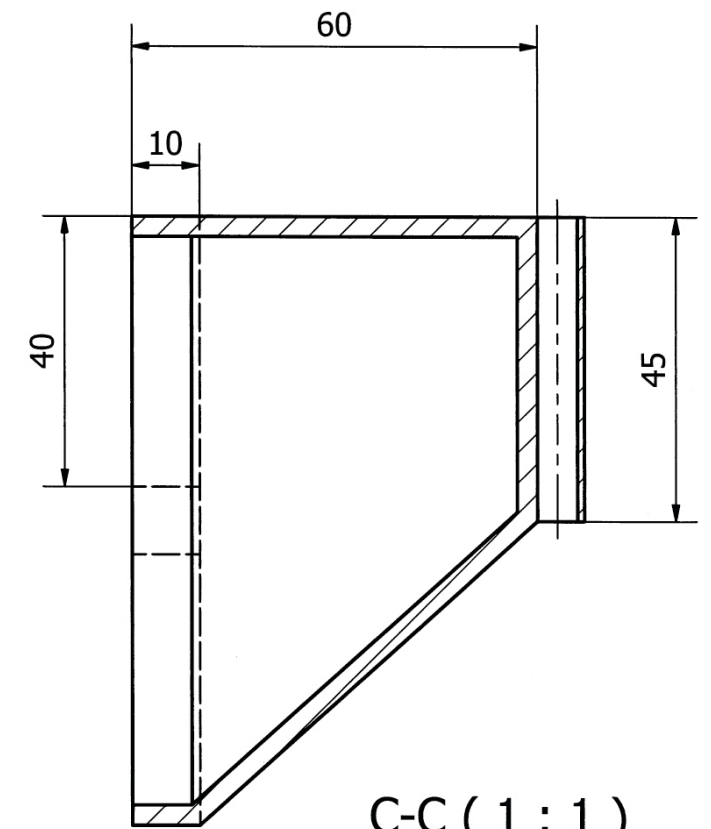

C-C (1:1)

SECTIONAL END ELEVATION

Designed by	Checked by	Approved by	Date	Date	
				24/08/2018	
			Speaker Drawing Views		Edition
					Sheet 1 / 4

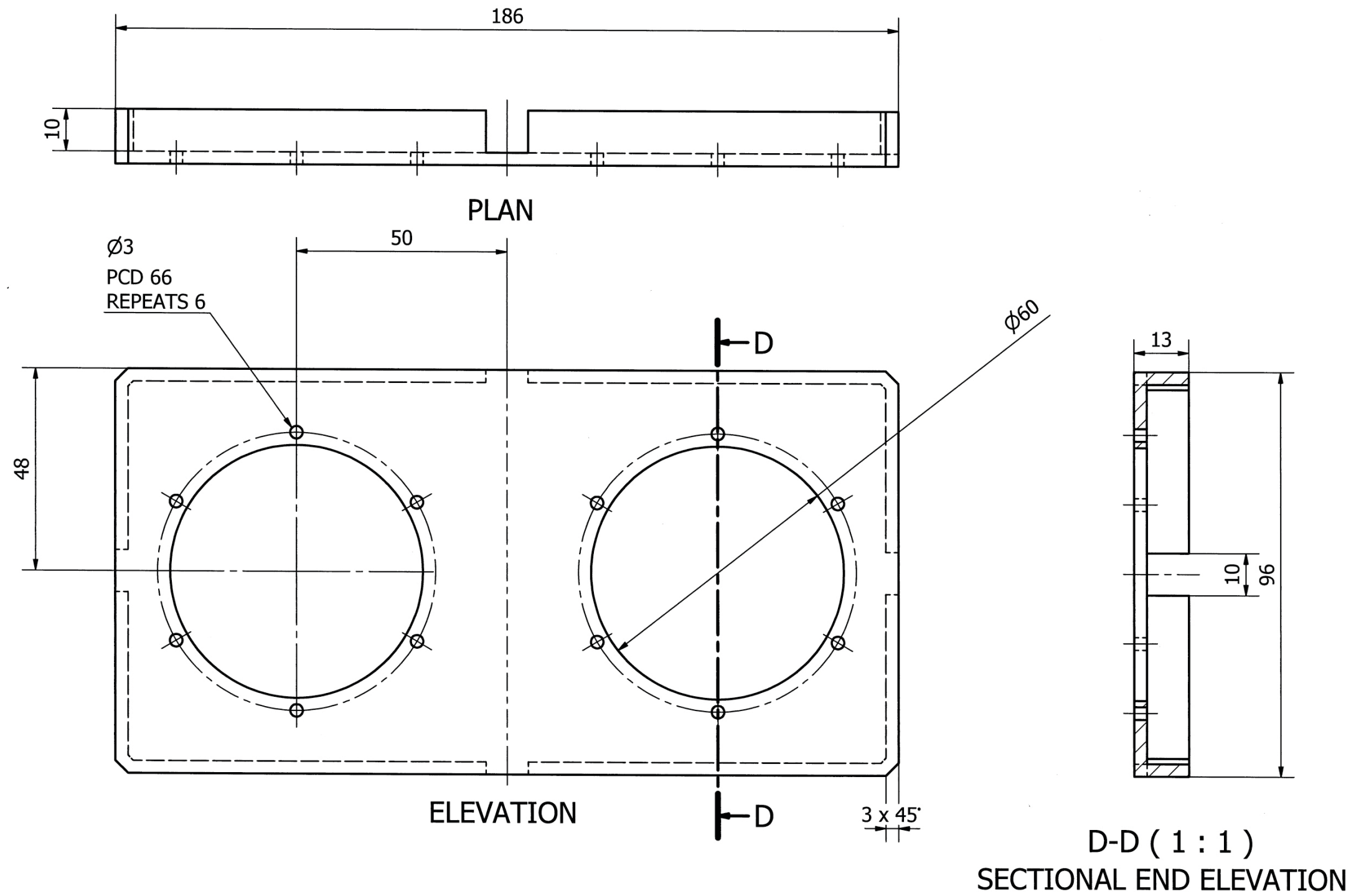

Designed by ██████████	Checked by	Approved by	Date	Date	
				24/08/2018	
			Speaker Drawing Views		
			Edition	Sheet	
				2 / 4	

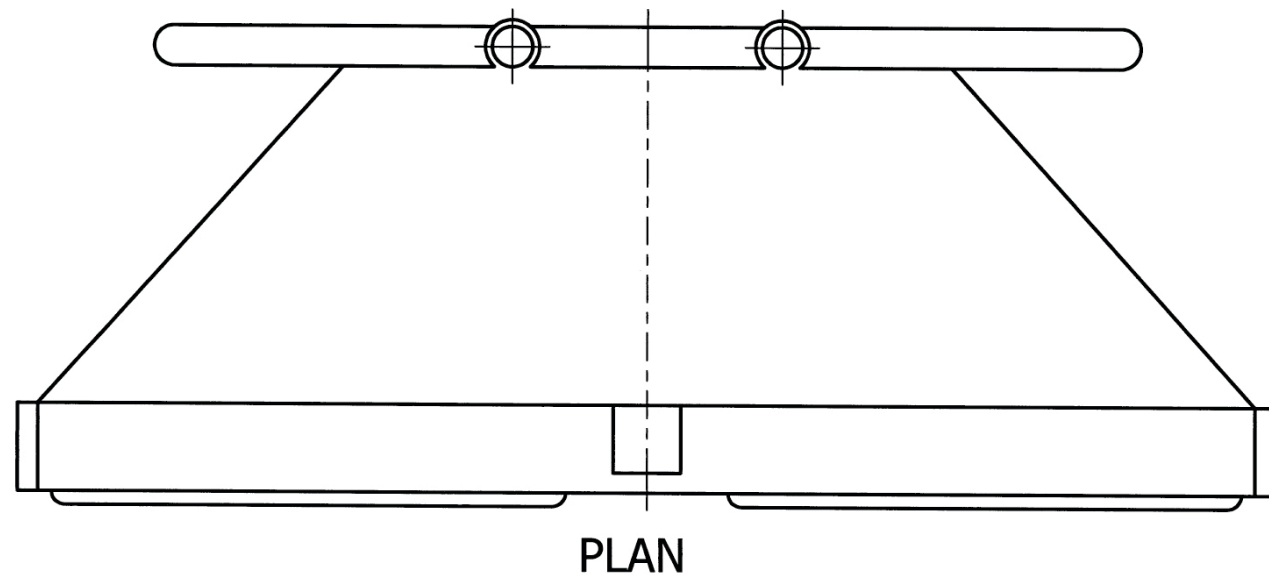

F (1 : 1)

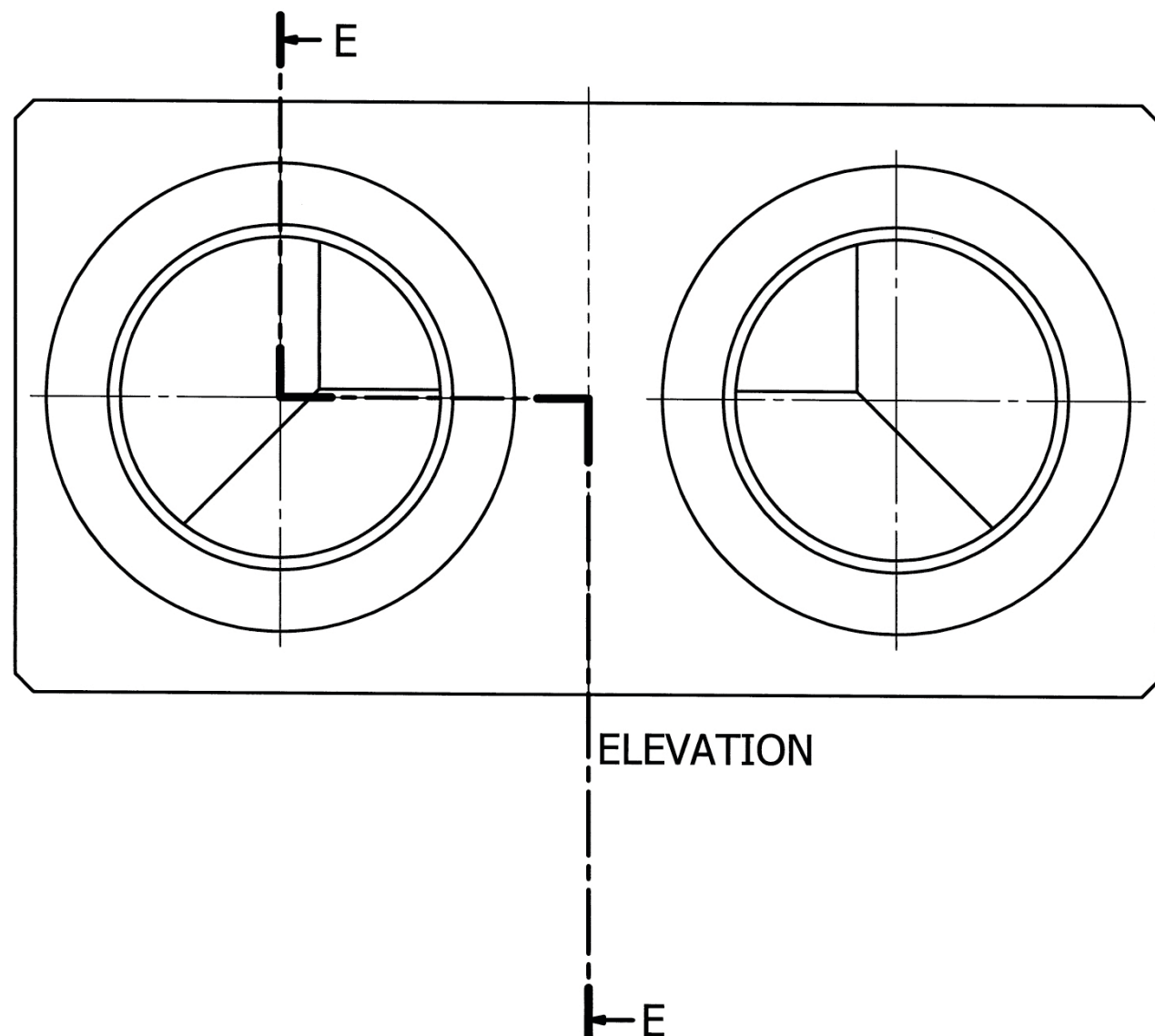
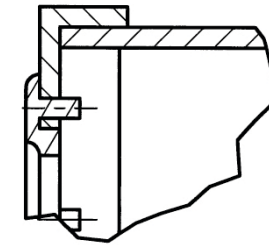

F E-E (1 : 1)

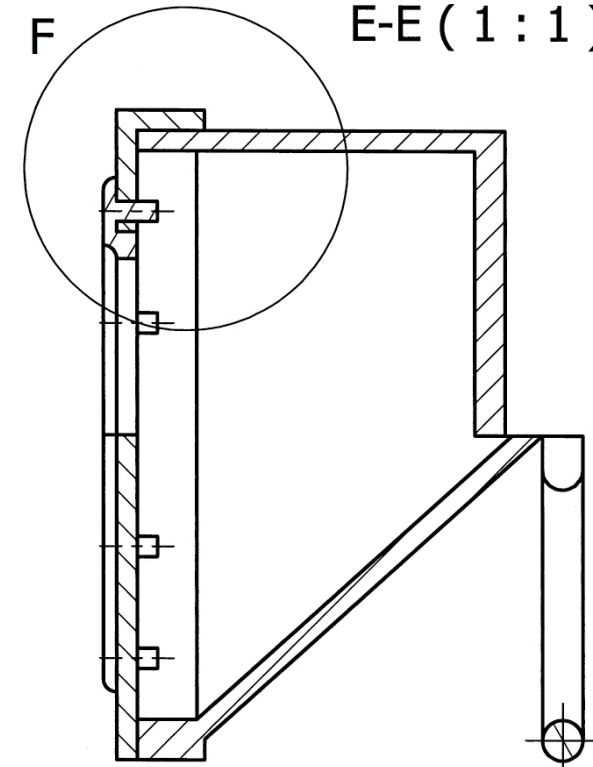

SECTIONAL END ELEVATION

Designed by ██████████	Checked by	Approved by	Date	Date 24/08/2018	
			Speaker Drawing Views		

EXPLODED ISOMETRIC
VIEW 1:1

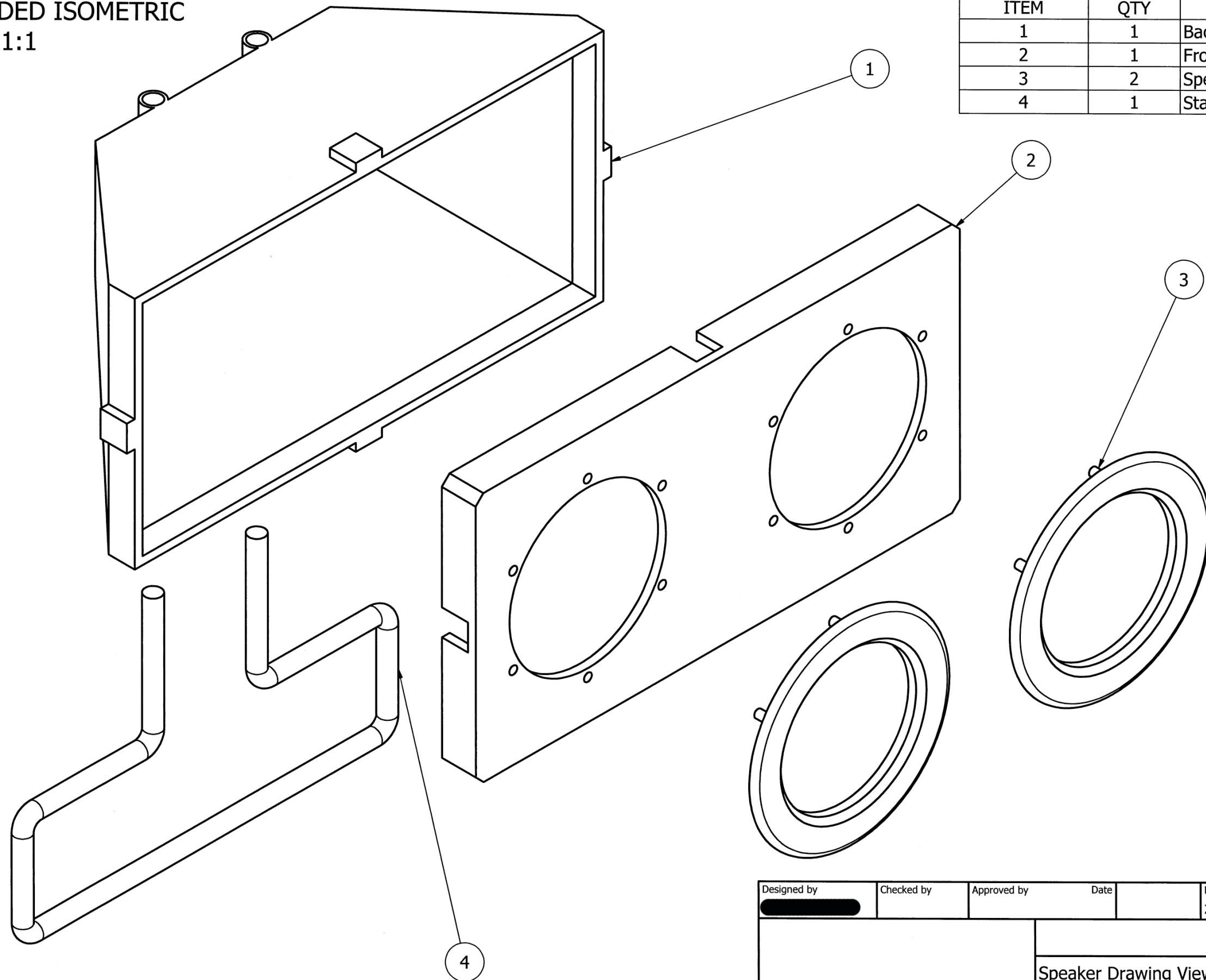

PARTS LIST		
ITEM	QTY	PART NAME
1	1	Back Casing
2	1	Front Casing
3	2	Speaker Disc
4	1	Stabilising Rod

Designed by	Checked by	Approved by	Date	Date	
				24/08/2018	
			Speaker Drawing Views	Edition	Sheet
					4 / 4

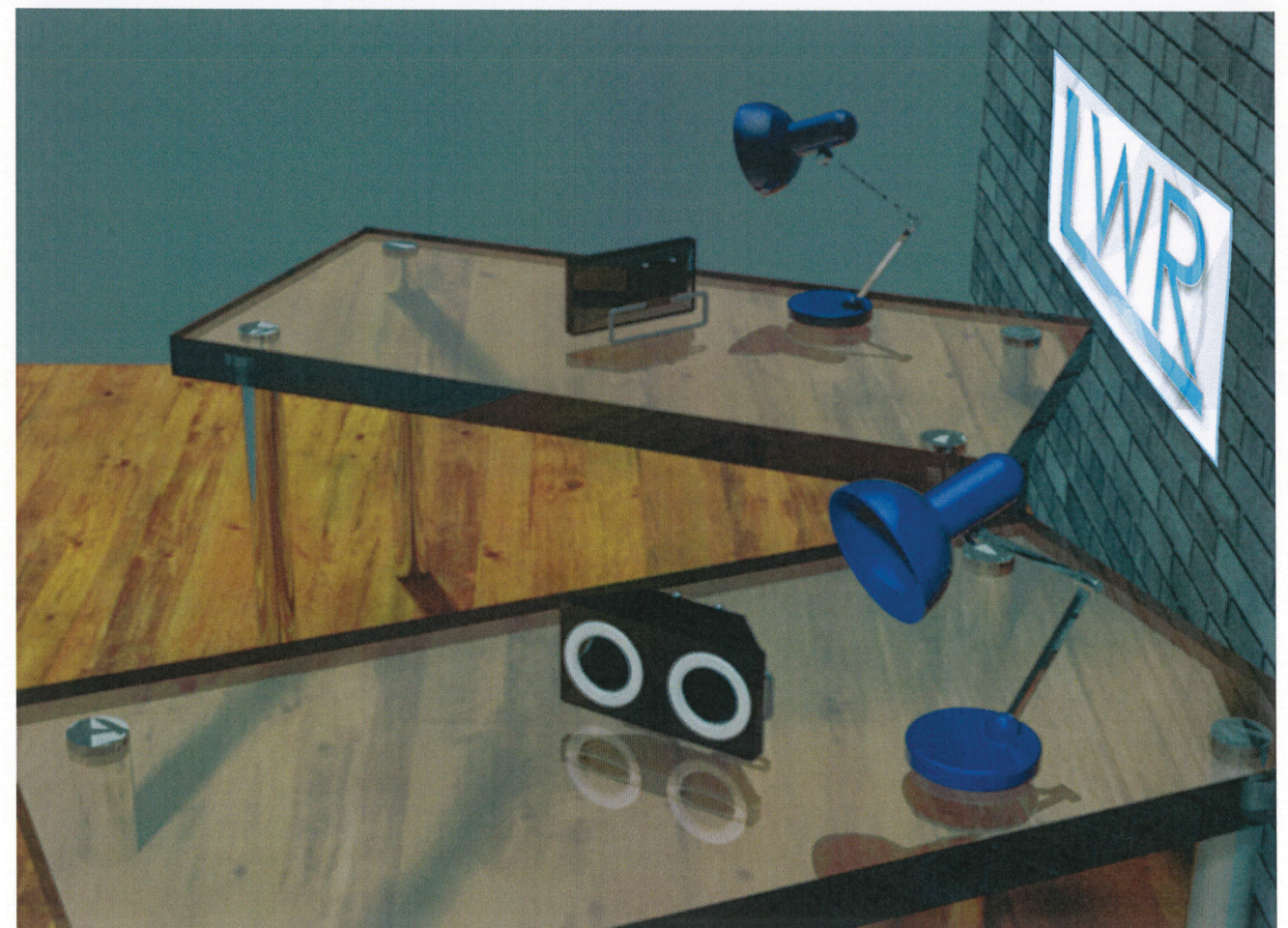
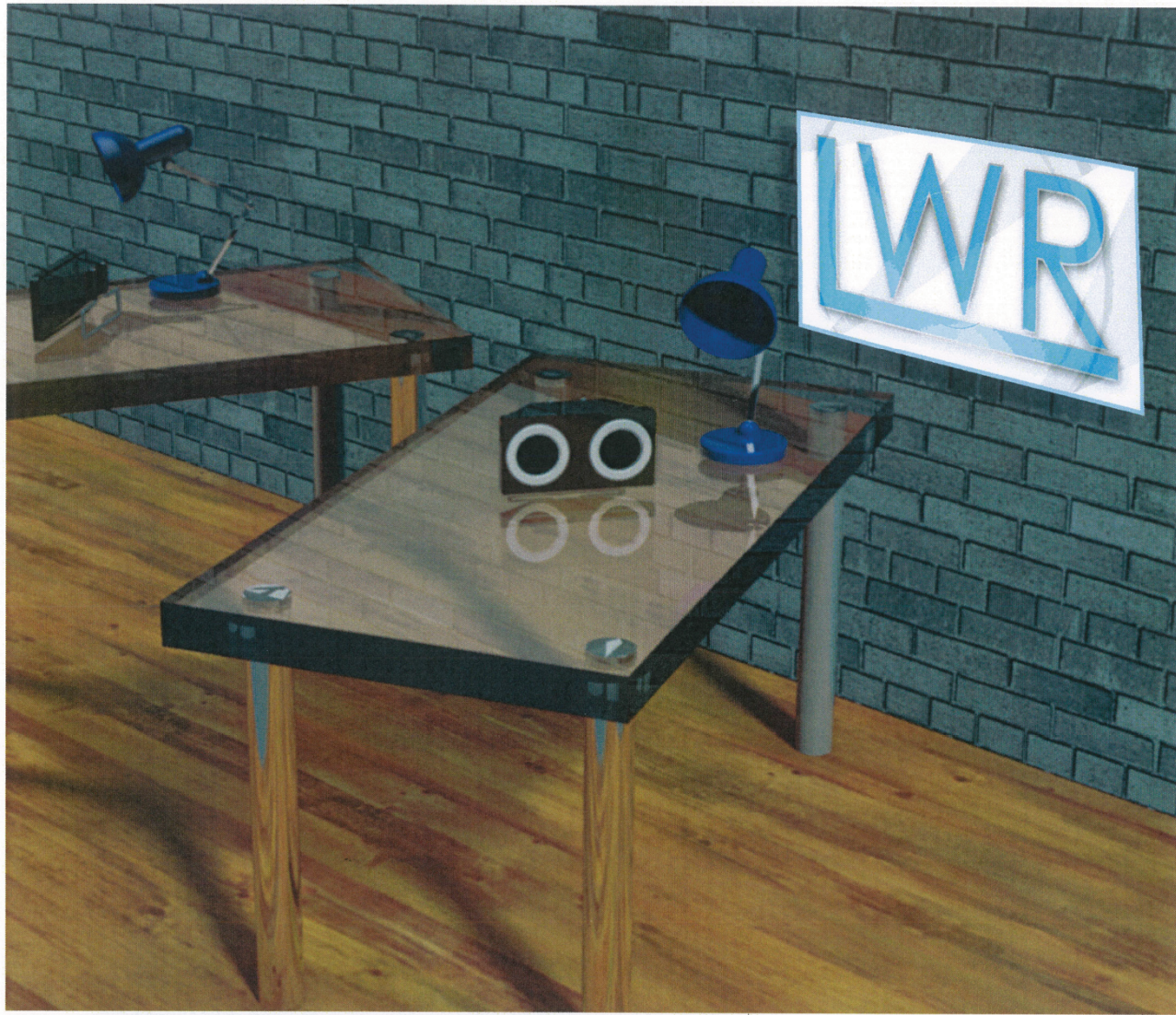

Layout 1

Done in the company's orange colour

bleeding onto the next page pulling them both together

Mixing Desk as a the background

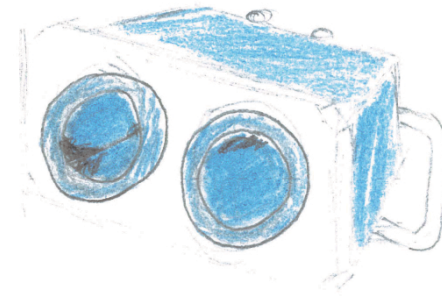
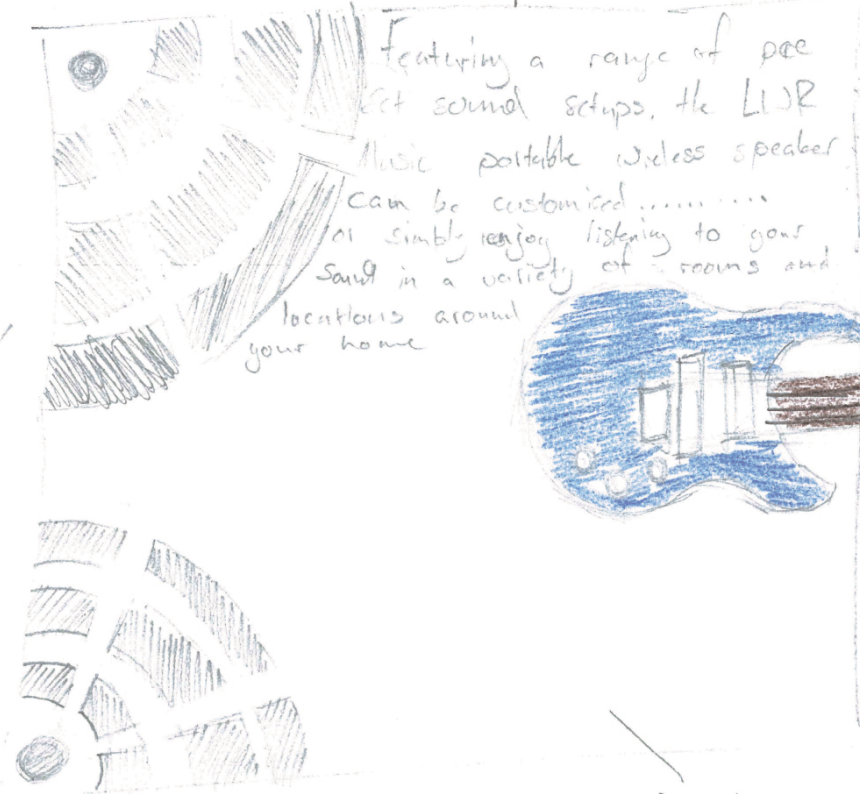

The LWR Music portable wireless speaker remains lightweight The twin speaker setup produces clean vocal sound and boasts powerful

Done in the company's pink colour

repetition

Condenser microphone with transparency as background

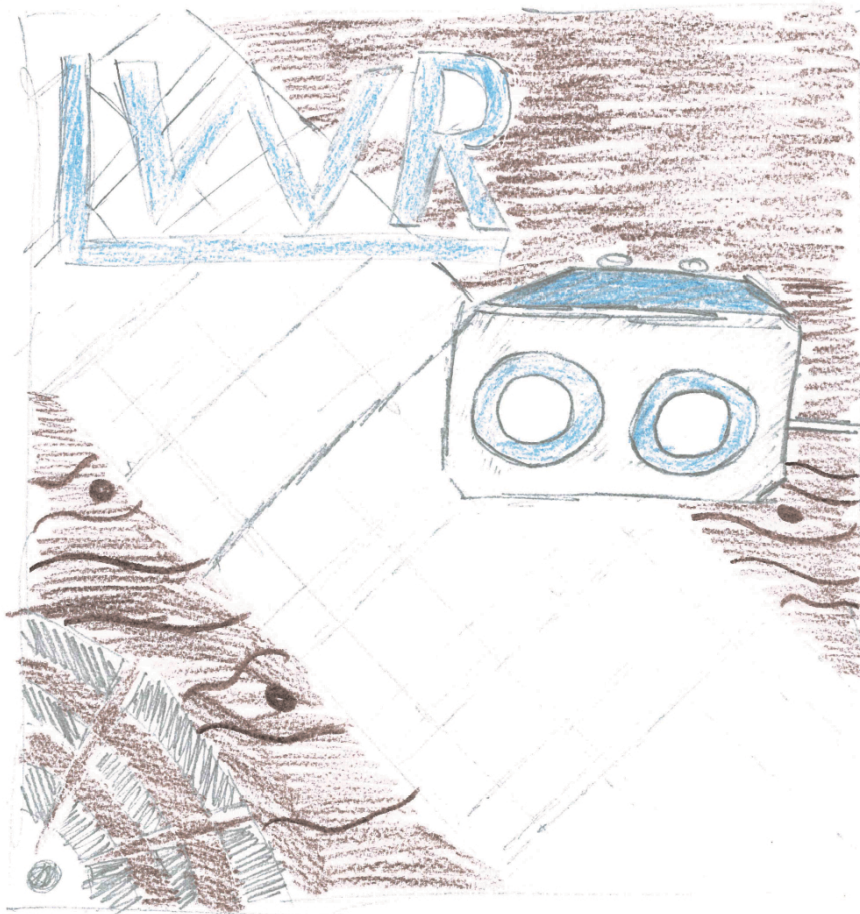

guitar strings bleeding from the front of the cabinet onto the back

The musician's wingman this portable speaker features electric and bass guitar connectivity. This allows you to connect your instruments (using a mobile phone app)

Visit our website www.lwrmusic.co.uk for more details on this product

Guitar stem from the electric guitar image along with the wooden flooring as a background

wsap text

Done in the company's blue colour

layout 2

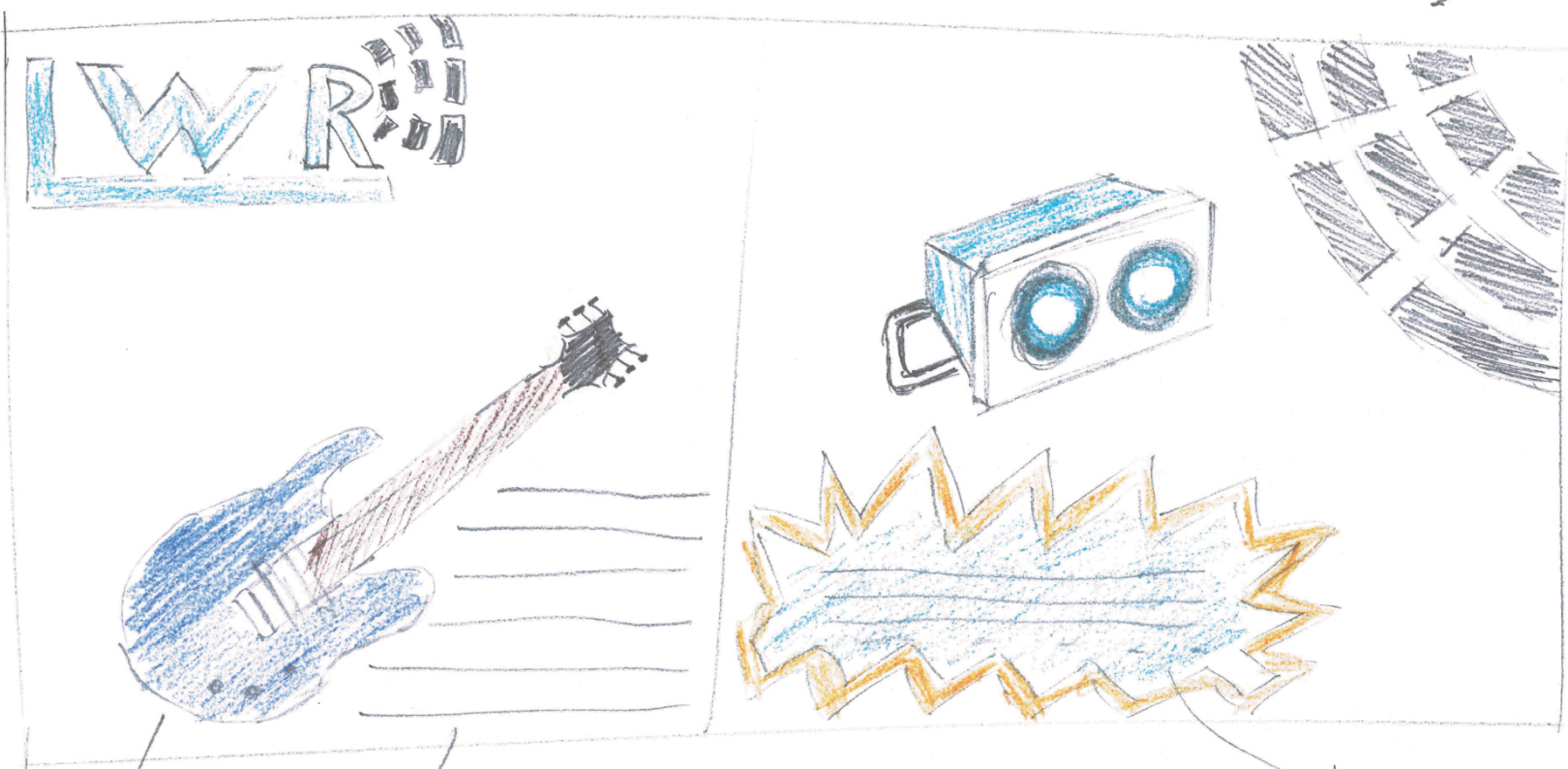

Rhythm through the repetition of wireless symbol

Drop shadows to also create depth

text describing the speaker

text talking about the functions of the speaker

Front

Back

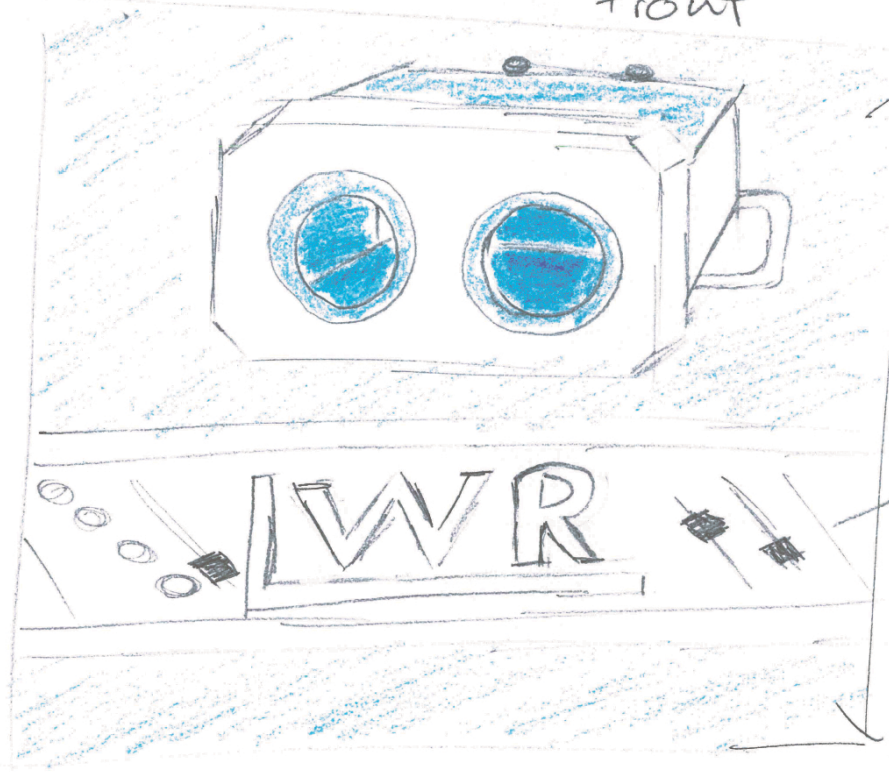

blue colour that is provided

Mixing Deck

blue colour provided text that involves the

orange back ground the same colour as said at the back

Picture of the acoustic guitar to create depth

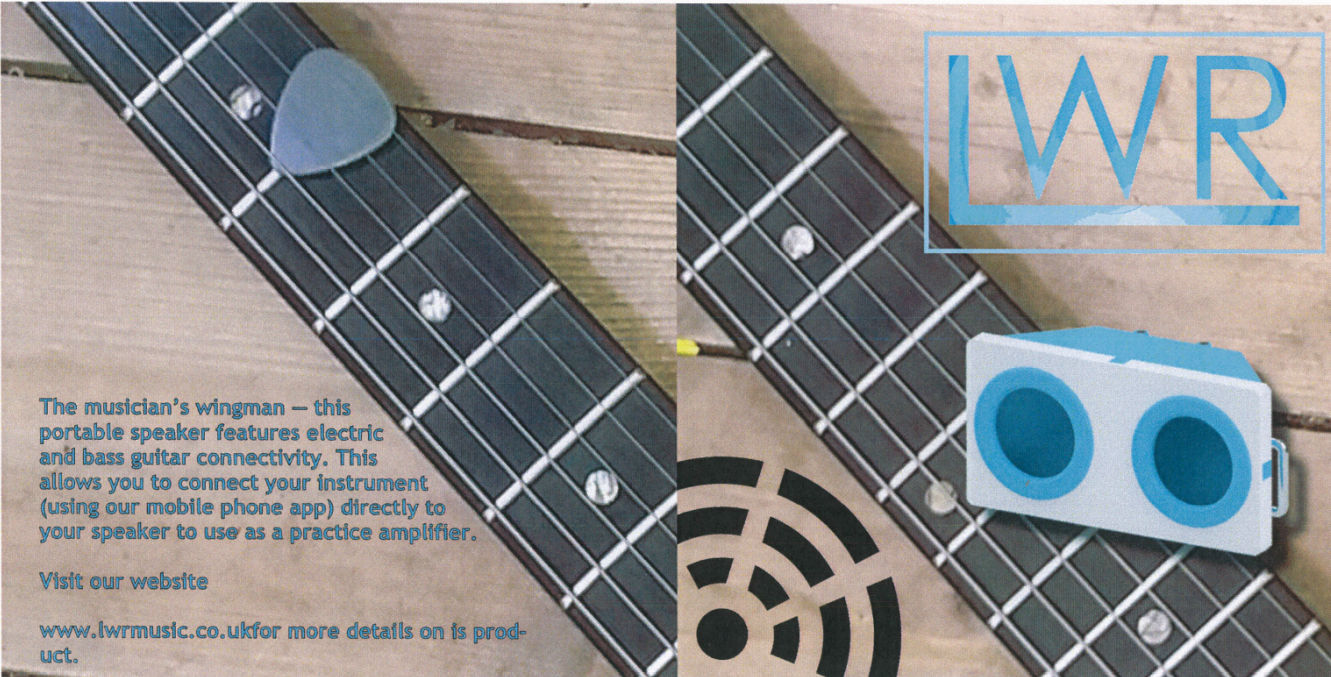

The musician's wingman – this portable speaker features electric and bass guitar connectivity. This allows you to connect your instrument (using our mobile phone app) directly to your speaker to use as a practice amplifier.

Visit our website

www.lwrmusic.co.uk for more details on this product.



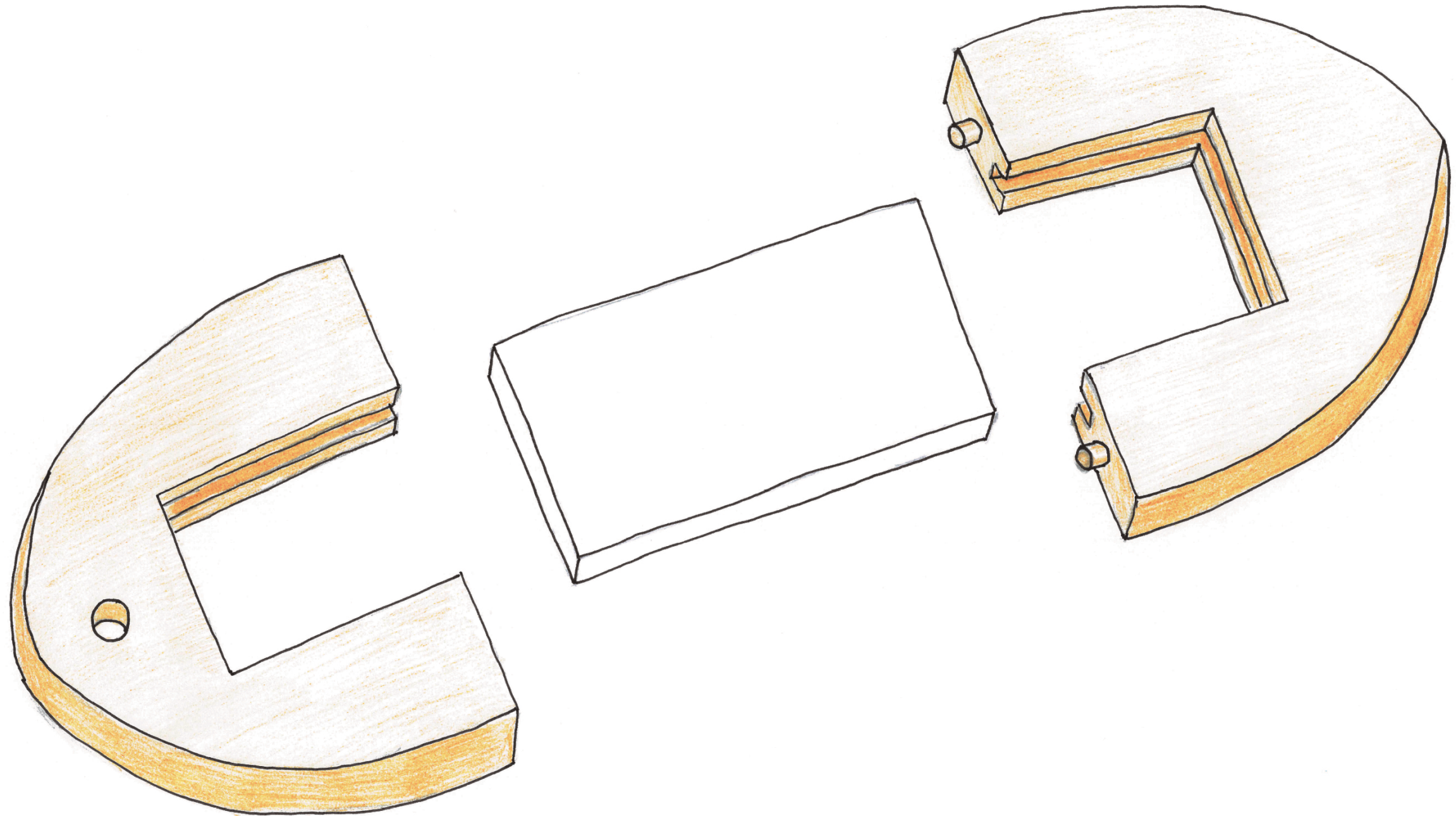

Colour Fill and Transparency: it gives the design a faded look but also again makes the readers eyes follow the page from left to right.

Flow text: to get the readers eyes to follow the page.



Drop Shadow: to give the design depth making the microphone and the guitar look like they are coming out of the page